

University of West Bohemia
Faculty of Applied Sciences

Dissertation thesis

2012

Ing. Jan Široký

University of West Bohemia
Faculty of Applied Sciences

Active fault detection and control

Ing. Jan Široký

A dissertation submitted in partial fulfilment
of the requirements for the degree of
Doctor of Philosophy
in
Cybernetics

Advisor: Prof. Ing. Miroslav Šimandl, CSc.
Department: Department of Cybernetics

Pilsen 2012

Západočeská univerzita v Plzni
Fakulta aplikovaných věd

Aktivní detekce poruch a řízení

Ing. Jan Široký

disertační práce
k získání akademického titulu doktor
v oboru Kybernetika

Školitel: Prof. Ing. Miroslav Šimandl, CSc.
Katedra: Katedra kybernetiky

Plzeň 2012

Declaration

I declare that this thesis entitled "*Active fault detection and control*" is the result of my own research except as cited in the references. The thesis has not been accepted for any degree and is not concurrently submitted in candidature of any other degree.

In Pilsen, 21.12.2012

Signature

Acknowledgment

Foremost, I would like to express my sincere gratitude to my advisor Prof. Miroslav Šimandl for the continuous support of my PhD study and research. His guidance helped me in all the time of research and writing of this thesis. Besides my advisor, I would like to thank to my colleague Ivo Punčochář for his help and valuable hints.

My sincere thanks also goes to colleagues from CTU Prague: Jiří Cigler, Samuel Prívarva, Zdeněk Váňa and Lukáš Ferkl, for the fruitful collaboration in field of predictive building control. Also I thank my colleagues from ETH Zürich: Frauke Oldewurtel, Dimitrios Gyalistras and Daniel Axehill, for the introduction to various topics related to model predictive control and their continuous support during my internship at ETH Zürich.

My thanks go also to co-workers from the company Energocentrum Plus. In particular, I am grateful to the managing director Petr Kudera that enabled me to combine work with studies.

Last but not the least, I would like to thank my family for their support.

Annotation

The dissertation thesis deals with the constrained optimization based approach to active fault detection and control (AFDC) of dynamical systems. The thesis addresses three main goals. The first goal is to define a general AFDC framework for stochastic discrete time dynamic system. The AFDC framework covers previously published formulations of AFDC as well as newly introduced formulations. The AFDC problems are defined as constrained optimization problems. The second goal is to derive a solution of AFDC problems. The optimal solution can be derived for a small subset of AFDC problems. Therefore, the focus is laid on a numerically tractable suboptimal solution for a practically important subclass of AFDC problems. The third goal of the thesis is to demonstrate the proposed AFDC framework. Basic properties of the proposed AFDC framework are illustrated by simple numerical examples. Main advantages of the proposed AFDC framework are demonstrated by a complex example, where the goal is simultaneous AFDC of an air handling unit.

Anotace

Disertační práce se zabývá aktivní detekcí poruch a řízením (ADPŘ) dynamických systémů s využitím matematické optimalizace s omezením. Disertační práce si klade tři hlavní cíle. Prvním cílem je formulace obecného rámce pro definování problémů ADPŘ pro stochastické diskrétní dynamické systémy. Obecný rámec ADPŘ pokrývá jak některé již publikované formulace, tak i nově představené formulace. Problémy ADPŘ jsou formulovány jako optimalizační úlohy s omezením. Druhým úkolem je odvození řešení pro problémy ADPŘ. Optimální řešení může být odvozeno pouze pro malou podskupinu problémů ADPŘ. Pozornost je proto zaměřena na odvození numericky spočitatelného sub-optimálního řešení pro podskupinu problémů ADPŘ, která má široké uplatnění v praxi. Třetím úkolem je demonstrace nově představeného rámce ADPŘ. Základní vlastnosti nově představeného rámce ADPŘ jsou ilustrovány pomocí jednoduchých příkladů. Hlavní výhody jsou poté demonstrovány na základě komplexnějšího příkladu, který se zaměřuje na ADPŘ klimatizační jednoty.

Contents

1	Introduction	1
2	Fault detection methods	4
2.1	Passive fault detection	6
2.1.1	Signal based methods	6
2.1.2	Model based methods	9
2.2	Active fault detection	11
2.2.1	Stochastic approach	12
2.2.2	Robust approach	13
3	Goals of the thesis	16
4	General framework for active fault detection and control	18
4.1	Active fault detection and control framework	18
4.1.1	Observed and controlled system	19
4.1.2	Detector and controller	19
4.1.3	General criterion	20
4.1.4	Constraints	21
4.1.5	Problem formulation	22
4.2	Special cases	23
4.3	Discussion	27
5	Optimal solution	30
6	Suboptimal solution	34
6.1	Approximate dynamic programming	34
6.1.1	Rollout algorithm	34
6.1.2	Restricted structure policies	35
6.1.3	Open loop strategy	35
6.2	Design of suboptimal active fault detection and control	37
6.2.1	Problem formulation	37
6.2.2	Solution for open loop strategy	39

7	Numerical example	48
7.1	Objective function and constraint sets demonstration	48
7.2	Simple active fault detection and control problem	49
8	Air handling unit numerical example	55
8.1	Overview of building control and fault detection methods	55
8.1.1	Building fault detection	56
8.1.2	Optimization based building control	56
8.2	Air handling unit model	58
8.3	Air handling unit experiments	60
8.3.1	Experiments setup	61
8.3.2	Cold morning experiments	62
8.3.3	Warm morning experiments	66
8.3.4	Monte Carlo verification	69
8.4	Discussion	72
9	Conclusion	73

Chapter 1

Introduction

Control engineering has an essential role in a wide range of control systems, from simple household washing machines to high-performance F-16 fighter aircrafts. Correct functioning of control systems is of great importance. Therefore an integral part of almost any control system is a fault detector. Various techniques can be used for fault detection from a straightforward limit checking to advanced techniques such as a constrained active fault detection (AFD) described in the thesis.

Research and development of fault detection methods is driven mainly by safety requirements, but its economical impact is also important. Proper failure handling is crucial for safety-critical automated processes such as in chemical plants, nuclear power plants or aircrafts where an unhandled failure can have catastrophic consequences. To underline importance of fault detection, several avoidable catastrophes are mentioned. In the Netherlands in 1992, the cargo plane Boeing 747-200F crashed into two high-rise apartment complexes causing lot of casualties, see Figure 1.1. The catastrophe was caused by a serious engine failure, however, according to paper [Maciejowski and Jones, 2003] there was a possibility to land safely back to Amsterdam Schiphol Airport. Another example is from Chicago in 1979. Investigation of airplane crash showed that the crash could have been avoided despite the fact that the pilot had just 15 seconds to react [Montoya et al., 1983]. Consequences of lacking fault detection in chemical industry can be even more disastrous. One of the the largest industrial disaster happened in 1884 in Bhopal, India. A leak of methyl isocyanate gas and other chemicals from a plant resulted in at least 4 000 casualties [Eckerman, 2005]. Fault detection is no longer limited to aforementioned high-end systems. For example, automobiles are increasingly dependent on automation and therefore on fault detection as well.

Failures of automatic systems cause also significant economical losses that can be avoided when a fault is detected in time and proper actions are taken. According to [Venkatasubramanian et al., 2003], petrochemical industry in the US incurs approximately 20 billion dollars in annual losses due to poor abnormal event management. The American Society of Heating, Refrigerating and Air-Conditioning Engineers (ASHRAE) estimates that poorly maintained, degraded, and improperly controlled heating, ventilation, and air conditioning (HVAC) equipment wastes an estimated 15% to 30% of energy used in commercial buildings [Katipamula and



Figure 1.1: Aftermath of the cargo plane Boeing 747-200F crash.

Brambley, 2005]. Fault detection can also provide valuable information about degradation of appliances. Maintenance and service costs can be reduced when level of degradation is considered while scheduling service actions. Some fault detection methods can also help to locate a failure, explain the cause of the failure or predict possible subsequent scenarios.

Fault detection is done by fault detectors. A fault detector provides an information about a potential failure of a monitored system based on measured data. The fault detector uses some form of knowledge about fault free and faulty behavior of the monitored system. This information is utilized during evaluation of measured data, e.g., mean value of the measured signal is compared with an expected value or the measurements are compared with values predicted using a detailed mathematical model. Most of fault detectors evaluate the measured data without affecting the monitored system. These fault detectors that only passively analyze the measured data are denoted as *passive detectors*. Passive fault detectors are widely used and they provide the required detection reliability in most applications. However, in some situations, the passive detector can have insufficient amount of information for a reliable decision about a potential failure. This drawback is addressed by the AFD approach. An *active fault detector* excites the monitored system in order to receive information about the monitored system's static, dynamic or frequency characteristics in order to provide a more reliable fault detection. Excitation has to be done carefully with respect to all limitations of the monitored system. The excitation of the monitored system is usually in contradiction to control objectives. A subset of AFD problems where the simultaneous design of active fault detection and control is explicitly addressed is denoted as *active fault detection and control* (AFDC) and it will be investigated in the thesis.

A mathematical formulation and numerical solution of the AFDC problems is a non-trivial task, however, almost every human deals intuitively with AFDC problems in everyday life as is demonstrated by the following example that focuses on a potential car brake failure. A responsible driver performs a small brake test when there is any suspicion about the breaks operation, especially when a steep descent

is ahead. This procedure costs a bit of fuel and driving time but this is negligible compared to the complications that can arise from underestimation of potential break failure. The goal of the AFDC is to introduce this “suspicious factor” into detection and control systems and to actively excite the monitored system in order to minimize uncertainty in the decision making process. One can imagine, that lot of questions may arise in the break testing example: What is the optimal trade off between speed loss and a sufficiently convincing break test? Is it safe to perform the break test? Is it necessary to perform the break test at all? etc. The approach that will be described in the thesis does provide a rigorous apparatus that addresses such questions.

The thesis is further organized as follows. An overview of the history of fault detection and classification of fault detection methods is given in the second chapter. Special attention is laid on AFD. Goals the thesis are formulated in the third chapter. In the fourth chapter, a general framework of AFDC is formulated and several special cases are derived. An optimal solution of AFDC problems is presented in the fifth chapter. Since, the vast majority of AFDC problems is numerically intractable, the design of a numerically tractable suboptimal solution is discussed and illustrated using a particular AFDC problem in the sixth chapter. In the seventh chapter, basic properties of AFDC problems are illustrated by means of simple numerical examples. More complex example that focuses on control and detection of an air handling unit is given in the eighth chapter. The ninth chapter concludes the thesis and outlines further applications of AFDC.

Chapter 2

Fault detection methods

The origin of fault detection methods can be dated to the end of the 19th century when instrumented machines used limit checking. For the supervision of plants the use of ink and later printing recorders was standard equipment since about 1935, [Isermann, 2006]. Transistor based amplifiers and sequential controllers that became available about 1960 allowed for realization of more advanced techniques. The early methods used the principle of *hardware redundancy*, i.e., one quantity is measured by several sensors and the measured data are continuously compared, [Hajiyev and Caliskan, 2003]. A fault is detected if there is a major disproportion in the measured values. Hardware redundancy increases installation costs and space requirements but it is a robust technique and therefore it is still used in critical processes. For example, military aircrafts and new generation civil aircrafts such as Boeing 777 or Airbus A320/330/340/380 have triplex or quadruplex-redundant actuation systems as well as sensor systems [Zhang and Jiang, 2008].

Introduction of programmable logical controllers and microcomputers in the early seventies of the 20th century gave a rise to computationally more involved fault detection algorithms based on *analytical redundancy*. These methods use some prior information that is incorporated into an algorithm that evaluates measured data. The first methods were based on analyzing signal properties [Wald, 1945, Basseville and Nikiforov, 1993]. More advanced techniques are using a model of the monitored system in order to detect a failure. For a detailed overview of the history of fault detection methods see survey papers [Willsky, 1976, Isermann, 1984, Zhang and Jiang, 2008]. One of the recent contributions to fault detection was the introduction of AFD and AFDC.

Fault detection methods are used in a wide range of applications and therefore there are different requirements on fault detectors. For example, different fault detection demands can be expected in case of a supersonic plane and a building heating system. Nevertheless, several important requirements can be outlined even if some of them are in contradiction. The following summary of fault detection requirements is adapted from [Venkatasubramanian et al., 2003]

- **Quick detection and diagnosis**

Quick response to failures is crucial in critical applications such as aeronautics.

This requirement is usually in contradiction to noise insensitivity.

- **Isolability**

Isolability is the ability to distinguish between different faults.

- **Robustness**

A detector shall be robust to various noise and uncertainties and minimize the amount of false alarms.

- **Novelty identifiability**

Not all potential failures are known during a detector design. A detector can be designed such that it recognizes a faulty state even if the fault was not defined by a designer.

- **Classification error estimate**

An estimate of a classification error can be facilitated in a diagnostic system or by an operator.

- **Adaptability**

A detector shall be able to adapt to new operation conditions such as a change in production quantities.

- **Explanation facility**

Usage of artificial intelligence can provide an explanation facility. Such a detection system can explain causes of a failure, provide recommendations or predict possible consequences.

- **Modelling requirements**

A drawback of advanced fault detection model based techniques is the need for model construction. This procedure can be the most demanding part of fault detection system deployment.

- **Storage and computational requirements**

Another drawback of some of advanced fault detection techniques are overwhelming computational requirements. The active detection and control system presented in the thesis is one of such systems. The optimal solution presented in Section 5 is computationally intractable and the suboptimal solution presented in Section 6 results in a non-convex optimization problem.

- **Multiple fault identifiability**

When detecting more than one possible fault, it is important to take into account simultaneous faults. In general, the number of potential fault combinations is given as 2^N , where N is a number of single faults.

Besides these requirements presented in [Venkatasubramanian et al., 2003] it is also important to take into account implementation aspects. Simple methods, that can be easily implemented and verified are preferred. From this perspective, the technique that will be presented in the thesis is not preferable because it results in

a non-convex optimization problem that requires non trivial numerical tools. On the other hand, the AFDC method described in the thesis provides a high faults isolability, it can significantly increase detection time and estimate classification error.

Various classifications of fault detection methods can be found in literature. The interested reader is referred to monographs devoted to fault detection [Blanke et al., 2003, Basseville and Nikiforov, 1993, Patton et al., 1989, Gustafsson, 2000, Gertler, 1998, Isermann, 2006, Kerestecioglu, 1993, Campbell and Nikoukhah, 2004, Hajiyev and Caliskan, 2003]. In this chapter, two main categories that are distinguished are passive and active fault detection methods. The passive fault detection (PFD) methods do only passively evaluate measured data, see Figure 2.1(b). The AFD methods can actively influence a monitored system in order to improve detection, see Figure 2.1(b).

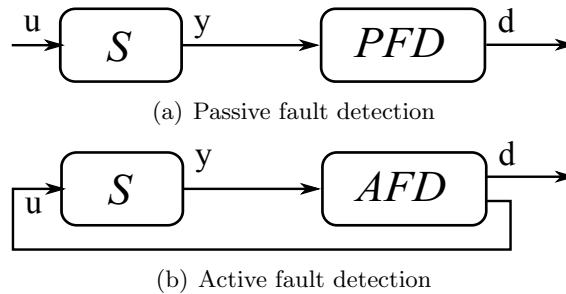

Figure 2.1: Comparison of passive fault detection and active fault detection.

2.1 Passive fault detection

In this section, a fault detection method classification from [Isermann, 2006] is adapted and presented. Two main PFD method categories are signal and model based methods. Both categories are shortly introduced and the important methods are mentioned. One representative method from both categories are described in detail and presented by a numerical example.

2.1.1 Signal based methods

The most simple and frequently used method for fault detection is the *limit checking*. The measured variables of a process are monitored and checked if their absolute values or trends exceed certain thresholds. *Absolute value checking* is applied in almost all process automation systems. Examples are the oil pressure (lower limit) or the coolant water (higher limit) of combustion engines, the pressure of the circulation fluid in refrigerators (lower limit) or temperature of heating water in central heating system (both limits). *Trend checking* is based on the analysis of the first derivative. Threshold values can be fixed or adaptive. Fixed thresholds are mostly selected based on experience.

Many processes are characterized by their oscillating behavior (rotating machines, alternating currents, ...). The resulting signals are then periodic signals or contain periodic parts. Fault detection methods of periodic signals are focused on frequency spectrum analysis. The classical method is to pass the signal through *bandpass filters* with different central frequencies [Randall, 1987]. The bandpass filters can be either analog or digital. *Fourier analysis* plays a key role in frequency spectrum analysis and it is used for fault detection as well. For analysis of non-stationary periodic signals the *short-term Fourier transform* and the *wavelet transform* can be used [Qian and Chen, 1996].

Random processes like acoustic noise, turbulence flow, on-off switch of many consumers in electrical or water networks result in stochastic signals. The stochastic signals are described with the aid of statistical methods and probability calculus. For fault detection, *hypothesis tests* can be applied known from the theory of statistics. In hypothesis testing one tests a hypothesis H_0 (no fault) against one or more alternative hypothesis H_1, H_2, \dots (fault) that are specified. For hypothesis testing many different methods were developed. Among the tests usually used for fault detection are *cumulative sum (CUSUM)*, *t-test*, *F-test* and *sequential probability ratio test (SPRT)* [Basseville and Nikiforov, 1993, Wald, 1945].

The author of the thesis had proposed several practically oriented improvements of hypothesis tests for fault detection. At first it was a combination of model and signal based approaches, where the result from model based detection was validated by an independent statistical test [Široký and Šimandl, 2007]. The other improvements were focused on the CUSUM test. A data-based procedure for tuning threshold for the CUSUM test was described in [Široký and Šimandl, 2008]. This work was further extended for the CUSUM test where the probability density functions are expressed as Gaussian sums [Šimandl et al., 2009].

The signal based methods are illustrated by the SPRT. This test is used in practice and it clearly illustrates the key principles of a hypothesis testing based approach to fault detection. It is worth mentioning that the first stochastic active fault detector was based on SPRT in [Zhang, 1989].

Sequential probability ratio test

Design of the SPRT starts with a pair of hypotheses H_0 and H_1 , where the H_0 hypothesis is that statistical properties of a measured signal can be described by a parameter Θ_0 , while the hypothesis H_1 is that the statistical properties of the measured signal can be described by a parameter Θ_1 .

At each time step, the statistic Λ_k is evaluated as

$$\Lambda_k = \ln \frac{p(y_0^k)|_{\Theta_1}}{p(y_0^k)|_{\Theta_0}}, \quad (2.1)$$

where y_0^k presents the measurement from time 0 to time k and $p(y_0^k)|_{\Theta_j}, j = 0, 1$ is probability density function (pdf) expressing probability of measurement y_0^k when hypothesis H_j is correct. Conditional probability density function (pdf) $p(y_0^k)|_{\Theta_j}$

can be expressed as a product of conditional pdfs $p(y_0^k)|_{\Theta_j} = \prod_{t=0}^k p(y_t|y_0^{t-1})|_{\Theta_j}$. Equation (2.1) can then be written as

$$\Lambda_k = \ln \frac{\prod_{t=0}^k p(y_t|y_0^{t-1})|_{\Theta_1}}{\prod_{t=0}^k p(y_t|y_0^{t-1})|_{\Theta_0}} = \sum_{t=0}^k \ln \frac{p(y_t|y_0^{t-1})|_{\Theta_1}}{p(y_t|y_0^{t-1})|_{\Theta_0}}. \quad (2.2)$$

The statistic Λ_k can be computed recursively as

$$\Lambda_k = \Lambda_{k-1} + \ln \frac{p(y_k|y_0^{k-1})|_{\Theta_1}}{p(y_k|y_0^{k-1})|_{\Theta_0}}, \quad (2.3)$$

with the initial condition $\Lambda_{-1} = 0$. At each time step, the statistic Λ_k is compared with two thresholds A and B in the following way

- if $\Lambda_k \geq A$, hypothesis H_1 is accepted,
- if $\Lambda_k \leq B$, hypothesis H_0 is accepted,
- if $A < \Lambda_k < B$, none of hypothesis is accepted and measurement continues.

The threshold values can be set according to requirements on Type I and Type II errors. A type I error, also known as a false positive, occurs when a statistical test rejects a true null hypothesis H_0 . A type II error, also known as a false negative, occurs when the test fails to reject a false null hypothesis H_0 . The required probability of Type I error will be denoted as α_E and the required probability of Type II error will be denoted as β_E . The thresholds A and B can be then computed as follows

$$A = \ln \frac{1 - \beta_E}{\alpha_E}, \quad (2.4)$$

$$B = \ln \frac{\beta_E}{1 - \alpha_E}. \quad (2.5)$$

Numerical example 2.1 The SPRT will be illustrated by means of a simple example. The pdfs are Gaussian and the goal is to decide between two hypothesis that describe statistical properties of the measured signal. The hypothesis are the following

$$H_0 : y_k \sim N(\Theta_0, 1), \Theta_0 = 0 \quad (2.6)$$

$$H_1 : y_k \sim N(\Theta_1, 1), \Theta_1 = 0.5. \quad (2.7)$$

The source signal is Gaussian with mean value 0.5 and variance 1, i.e., there is a fault and H_0 shall be rejected. Two experiments were performed: a less restrictive test where $\alpha_E = \beta_E = 0.1$ (Figure 2.2(a)) and a more restrictive test where $\alpha_E = \beta_E = 0.01$ (Figure 2.2(b)). Each experiment comprised 1000 Monte Carlo simulations. There was 76 Type II errors in case of the less restrictive test and 9 Type II errors in case the more restrictive test. Monte Carlo simulations confirmed that SPRT meets Type I and Type II errors requirements. Decision are taken sooner in case of the less restrictive test. On the other hand, number of false decisions is higher in case of the more restrictive test. This illustrates the conflicting aims of quick detection and noise insensitivity.

2.1.2 Model based methods

Model based methods of fault detection use the relations between several measured variables to extract information on possible changes caused by faults. These relations are mostly analytic relations in form of process model equations. Special features like model parameters or state variables are extracted and compared with their nominal values by model based fault detectors.

In many cases the process models are not known exactly and have to be identified. Identification may be a source to gain information on process parameters that change under influence of faults. Fault detection methods that make use of model identification techniques are denoted as *parameter estimation* methods, [Ljung, 1987]. Parameter estimation can be done by various identification techniques from basic *least squares* to *State Space Subspace System identification*, [Overschee and Moor, 1993].

A straightforward way to detect process faults denoted as *parity equations* is to compare the process behavior with a process model describing the nominal, i.e., non-faulty behavior, [Gertler and Singer, 1990]. The difference of signals between the process and the model are expressed by residuals.

As *state observers* use an output error between a measured process output and an adjustable model output, they are a further alternative for fault detection, [Gertler, 1998]. It is assumed, as in the case of parity equations approaches, that the structure and parameters of the model are precisely known. State observers adjust the state variables according to initial conditions and to the time course of the measured input and output signals. Several approaches have been proposed for fault detection which are based on the classical *Luenberger state observer* or so-called *output observer*. In case of stochastic models, the state has to be estimated by a *state estimation filter*, [Gustafsson, 2000].

State estimation based fault detection will be presented by means of a numerical example. This fault detection method plays an essential role in the thesis because an active version of this detector will be derived.

State estimation based fault detection

At each time step $k \in \mathcal{T} = \{0, 1, \dots, F\}$ the monitored system is described by one of the following two discrete-time linear Gaussian models

$$\begin{aligned} \mathbf{x}_{k+1} &= \mathbf{A}_\mu \mathbf{x}_k + \mathbf{B}_\mu \mathbf{u}_k + \mathbf{G}_\mu \mathbf{w}_k, \\ \mathbf{y}_k &= \mathbf{C}_\mu \mathbf{x}_k + \mathbf{H}_\mu \mathbf{v}_k, \end{aligned} \tag{2.8}$$

where $\mu \in \mathcal{M}$ indicates the model in effect during the whole finite-time horizon, $\mathbf{x}_k \in \mathbb{R}^{n_x}$ denotes the state, $\mathbf{u}_k \in \mathbb{R}^{n_u}$ is the input and $\mathbf{y}_k \in \mathbb{R}^{n_y}$ is the output. The initial state \mathbf{x}_0 follows the Gaussian distribution with a known mean value $\hat{\mathbf{x}}_0$ and a covariance matrix Σ_{x_0} and the discrete random variable μ has a known distribution $P(\mu)$. The state noise $\mathbf{w}_k \in \mathbb{R}^{n_w}$ and measurement noise $\mathbf{v}_k \in \mathbb{R}^{n_v}$ are mutually independent white noises with the Gaussian distribution with zero means and unit covariance matrices. They are also independent of the initial state \mathbf{x}_0 and

variable μ . The matrices \mathbf{A}_μ , \mathbf{B}_μ , \mathbf{G}_μ , \mathbf{C}_μ , and \mathbf{H}_μ for $\mu \in \mathcal{M}$ are of appropriate dimensions and also known.

The goal is to decide which model is in action on the basis of noisy measurements and prior information. The decision is taken at the end of the prediction horizon. The decision d_F is given as follows

$$d_F = \arg \max_{\mu \in \mathcal{M}} P(\mu | y_0^F, u_0^{F-1}) . \quad (2.9)$$

The probability $P(\mu | y_0^k, u_0^{k-1})$ is computed recursively as

$$P(\mu | y_0^k, u_0^{k-1}) = \frac{p(\mu, y_0^k, u_0^{k-1})}{p(y_0^k, u_0^{k-1})} = \frac{p(y_k | \mu, y_0^{k-1}, u_0^{k-1}) P(\mu | y_0^{k-1}, u_0^{k-2})}{p(y_k | y_0^{k-1}, u_0^{k-1})} , \quad (2.10)$$

where the initial condition of the recursive equation is given by $P(\mu)$. A bank of Kalman filters is used for evaluation of the predictive measurement pdf $p(y_k | \mu, y_0^{k-1}, u_0^{k-1})$.

Table 2.1: Estimates of misclassification probability based on 10000 Monte Carlo simulations (Numerical example 2.2)

input signal	misclassification ($d_k \neq \mu$) probability estimate
u1	0.529
u2	0.422
u3	0.239
u4	0.178
u5	0.185
u6	0.235

Numerical example 2.2 The goal of the numerical example is to demonstrate the effect of the input signal profile on the detector performance. It will be shown that the reliability of passive detector is determined by the input signal profile.

Three models are considered ($\mathcal{M}=\{1,2,3\}$)

$$P(\mu = 1) = 1/3, A_1 = 0.4, B_1 = 1.2, C_1 = 1.0, \quad (2.11)$$

$$P(\mu = 2) = 1/3, A_2 = 0.6, B_2 = 0.8, C_2 = 1.0, \quad (2.12)$$

$$P(\mu = 3) = 1/3, A_3 = 0.8, B_3 = 0.4, C_3 = 1.0, \quad (2.13)$$

$$(2.14)$$

and $G_i = 1, H_i = 1, i \in \mathcal{M}$. Initial condition is given by $\hat{\mathbf{x}}_0 = 0, \Sigma_{x_0} = 0.5$. Six input signal profiles are investigated

- u1** zero signal,
- u2** constant signal with amplitude 2,
- u3** periodical signal oscillating between -2 and 2, period 12 time steps,
- u4** periodical signal oscillating between -2 and 2, period 6 time steps,
- u5** periodical signal oscillating between -2 and 2, period 4 time steps,
- u6** periodical signal oscillating between -2 and 2, period 2 time steps.

The input signals profiles are depicted in Figure 2.3. The goal of the detector is to decide after 12 time steps which model was in effect. The results that are based on 10000 Monte Carlo simulations are summarized in Table 2.1. The worst results are obtained when with input signal **u1**. The input is zero as well as the expected initial state $\hat{\mathbf{x}}_0$ and only the state noise excites the monitored system. Slightly better results are obtained when **u2** was used. All models have the same static gain, therefore, the models can be distinguished on the basis of different dynamics of transition from the initial state to the steady state. The periodical signals **u3-u6** excite the monitored system and the detector obtains more valuable information for decision. It can be seen that the best results were obtained when **u4** with period 6 time steps was used. Usage of the shorter as well as the longer period of the input signal resulted in a higher rate of misclassification. No general conclusion can be drawn from this empirical observation. Design of the optimal input signal for detection is a non-trivial task and it is determined by many factors such as a selected detector, system dynamic, noise characteristics, etc. Design of the optimal input signal for detection will be discussed in detail in the thesis and a method for design of optimal input signal for detection will be presented.

2.2 Active fault detection

Active fault detection has been studied for more than three decades. Various methods have been investigated but there is, to the best of the author's knowledge, no monograph nor survey paper devoted to AFD that summarizes and classifies all approaches to AFD. However, two main approaches to AFD can be distinguished, namely the stochastic approach and the robust approach. The origins and main contributions to both approaches are mentioned in this section.

2.2.1 Stochastic approach

The stochastic approach utilizes probabilistic description of model uncertainties. The solution is sought with respect to the known pdfs and probability mass functions that describe the stochastic counterpart of the model. Active fault detection of stochastic systems was inspired by optimal experiment design and design of optimal input signal for identification. The optimal designs are a class of experimental designs that are optimal with respect to some statistical criterion. The first article dealing with optimal experiment design was published in 1815 by Joseph Diaz Gergonne [Stigler, 1974] and this field has been intensively studied during the last 50 years [Kiefer and Wolfowitz, 1959]. The goal of design of optimal input signal for identification is excitation of an identified system in order to improve identification. The input signal has to respect limitation of the identified system such as input constraints or experiment cost. Review of the pioneering works is given in [Mehra, 1974, Zarrop, 1979].

The first article that deals with design of the optimal input signal for fault detection is [Zhang, 1989]. Design of auxiliary signal for improving SPRT fault detection, and the extension of the SPRT to multiple-hypothesis testing is presented in the paper. Improvement of statistical test used for fault detection by input signal design was discussed also in [Kerestecioğlu, 1993]. The goal was to improve the performance of the CUSUM test with respect to the average detection delay and required false alarm rate. In [Uosaki and Hatanaka, 2004], authors deal with design of optimal auxiliary input for fault detection based on Kullback divergence. Proposed input signal design was tested by the CUSUM test. The periodical signal was used for AFD in [Poulsen and Niemann, 2008]. The diagnosis is based on using both amplitude and phase information with respect to the signature in the residual output. Changes are detected and isolated by using a modified CUSUM test. In [Bateman et al., 2008], AFD is also based on an auxiliary periodical signal. The auxiliary signal is used for AFD of an unmanned aerial vehicle with redundant flight control surfaces.

Another approach to design control inputs in order to improve fault detection was introduced in [Blackmore and Williams, 2005]. The authors developed a new method that uses constrained finite horizon control design to create control inputs that minimize an upper bound on the probability of the model selection error. This approach was further extended for handling an arbitrary number of models [Blackmore and Williams, 2006, Blackmore et al., 2008].

There is also a significant Czech contribution to research on AFD of stochastic systems. Design of a suboptimal AFD system in multiple-model framework was studied in [Šimandl et al., 2005]. The optimal active detectors and the dual controller are discussed in [Šimandl and Punčochář, 2006]. A unified formulation of AFDC was introduced in [Šimandl and Punčochář, 2007] and further elaborated in [Šimandl and Punčochář, 2009]. The AFDC problem formulation stems from the optimal stochastic control problem and includes important special cases: an active detector and controller, an active detector and input signal generator, and an active detector with a given input signal generator. Another special case with a

given controller was discussed in [Punčochář et al., 2010]. The complete set of all variants that can be defined within the AFDC framework was presented in [Šimandl et al., 2011]. Nine special cases were defined and analyzed. Finally, the numerically tractable AFDC solution based on constrained optimization was presented in [Široký et al., 2011b].

2.2.2 Robust approach

An alternative to stochastic formulation is the robust approach to AFD, where the uncertainties are assumed to be bounded and guaranteed detection is sought. The early works [Nett et al., 1988, Jacobson and Nett, 1991] were focused on an integrated approach to control and fault detection using the four parameter controller structure. The interaction between detection and control module was studied. A nominal plant model as well as a model with uncertainty was considered. The early works were extended in [Tyler and Morari, 1994] where a recast of four the parameter controller allowed the employment of more general results studied in optimal H_2 and robust H_∞ control literature. It was also shown that an integrated approach using the H_2 performance measure for both controller and detector designs can be performed independently for nominal plants, but must be carried out simultaneously for those which contain structural uncertainty. The question of integrated fault detection and control design for models with uncertainties was further investigated in [Stoustrup et al., 1997, Niemann and Stoustrup, 1999]. In [Khosrowjerdi et al., 2004], AFDC¹ was formulated as a mixed H_2/H_∞ optimization problem and its solution was presented in terms of two coupled Riccati equations. Fault detection objectives were expressed by H_2 norm while H_∞ was used as a measure for control objective. The setup for AFD based on the Youla-Jabr-Bongiorno-Kucera parameterization was investigated in [Niemann, 2006, Niemann and Stoustrup, 2006]. A review of different robust AFDC design schemes and the evaluation of the diagnostic performance was given in [Ding, 2009].

An alternative approach to robust AFD is studied by Stephen L. Campbell and Ramine Nikoukhah. A theory of the auxiliary signal design for robust multi-model fault detection is given in monograph [Campbell and Nikoukhah, 2004]. It is assumed that there are two candidate models and the objective is to find an auxiliary signal of least energy and to perform a detection test during a test period that can guarantee the identification of the correct model. The auxiliary signal separates the sets of possible outputs of two models which represent nominal and faulty behaviors. This approach has been extended to include incipient faults [Nikoukhah et al., 2010], sampled systems [Nikoukhah and Campbell, 2005], systems with a priori information [Nikoukhah and Campbell, 2006] and discrete-time systems [Esna Ashari et al., 2011]. Detection of more than two incipient faults is presented in [Fair and Campbell, 2009]. The extension of robust approach for nonlinear system is can be found in [Andjelkovic et al., 2008].

¹In [Khosrowjerdi et al., 2004], AFDC is denoted as simultaneous fault detection and control (SFDC)

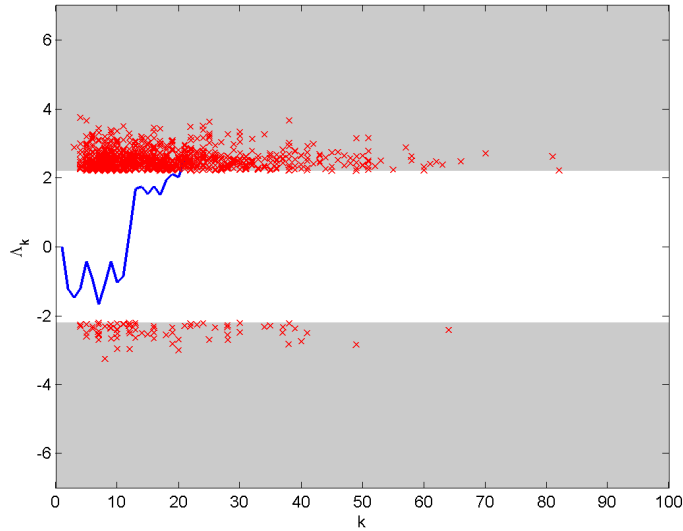

(a) Less restrictive test, $\alpha_E = \beta_E = 0.1$, 76 of 1000 simulations resulted in Type II error.

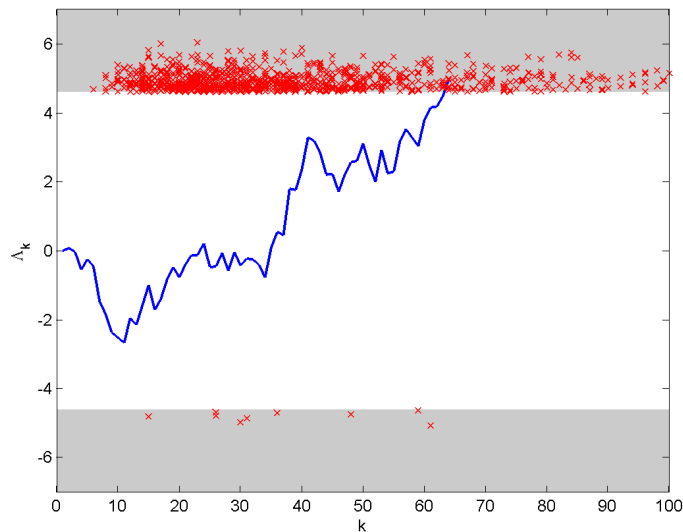

(b) More restrictive test, $\alpha_E = \beta_E = 0.01$, 9 of 1000 simulations resulted in Type II error.

Figure 2.2: Figures capture results of 1000 Monte Carlo simulations when H_1 was true. Blue line illustrates one test realization, while red crosses represents time steps and Λ_k values when any of the thresholds were crossed (Numerical example 2.1). The grey areas represent Λ_k values where some of thresholds is crossed. The red crosses in the top grey area represent correct decision (H_1 accepted), while the red crosses in the bottom grey are represent wrong decisions (H_0 accepted). It can be seen that decisions are taken sooner in case of the first (less restrictive) test. On the other hand there is also higher rate of Type II errors. Type I and II error requirements were fulfilled in both tests. Note that there was no Type I error since H_1 was always true.

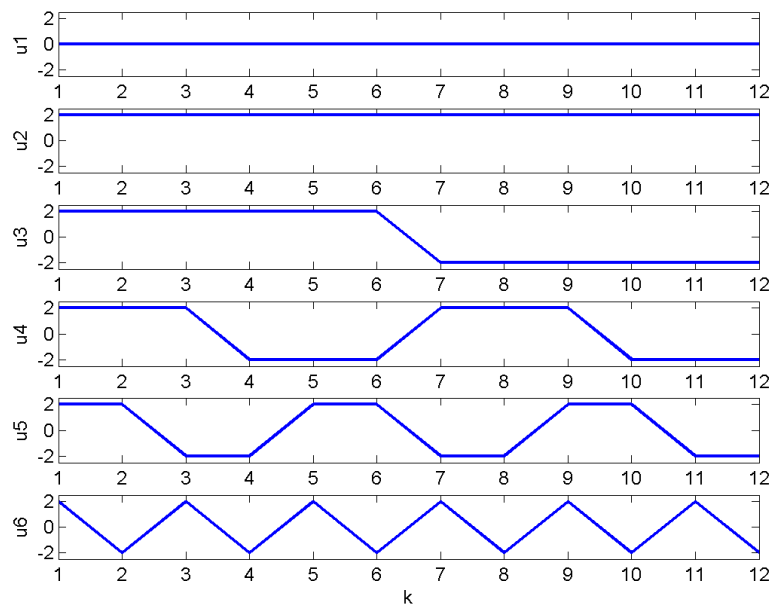

Figure 2.3: Input signal profiles (Numerical example 2.2).

Chapter 3

Goals of the thesis

The thesis focuses on AFD problems with special attention to handling of control. Two approaches to AFD can be distinguished: robust and stochastic. The robust approach to AFD has been intensively studied in literature as discussed in the previous chapter. In the thesis, the stochastic approach is addressed. In stochastic AFD, simultaneous design of active detector and controller is essential, however, most of the works on stochastic AFD problems published so far have not been focusing on rigorous handling of control objectives.

The branch of stochastic AFD that focuses on design of an auxiliary input signal for statistical tests does not directly address control objectives. The negative effect of an auxiliary input was considered in [Uosaki and Hatanaka, 2004], where “the auxiliary input should be chosen not to affect the model so much”. This aim was expressed as a maximal allowed deviation of the monitored system output with and without auxiliary input applied. Also the absolute value of the input signal was constrained. Maximum input power on an auxiliary signal within a certain frequency region was constrained in [Kerestecioglu, 1993]. Some of the works did not consider control objectives at all [Zhang, 1989, Poulsen and Niemann, 2008]. In general, it can be said that there is only a very limited apparatus for handling of control objectives within AFD based on statistical tests. In [Blackmore and Williams, 2005, Blackmore et al., 2008] a constrained optimization approach to AFD for multiple state-space models discrimination was introduced. It allowed handling of input constraints as well as expected states constraints, however, control aims were not considered. Explicit handling of control objectives in AFD stochastic problems was introduced in [Šimandl and Punčochář, 2009]. Problem of AFDC was formulated as an optimization problem using closed loop (CL) information processing strategy (IPS). Objective function expressed a required trade-off between detection and control aims. The AFDC optimization problem was solved by means of dynamic programming. Due to the complexity of the AFDC problem, the optimal solution can be computed for a short prediction horizon only. Moreover, only input constraints were considered in this AFDC formulation.

The main goal of the thesis is to overcome drawbacks of the aforementioned approaches and to formulate a general stochastic AFDC framework that will allow for a rigorous handling of detection and control aims. The focus will be laid on the

optimal solution as well as on a numerically tractable suboptimal solution of the defined AFDC problems. The main goal will be achieved by subsequent fulfillment of the following three sub-goals.

1 - Formulation of general active fault detection and control framework

The first goal of the thesis is to formulate a general AFDC framework that will allow a precise formulation of AFDC problems. The AFDC framework has to be able to handle common practical design requirements such as input and state constraints. Both detection and control aims have to be defined within one AFDC problem formulation. Besides handling of different AFDC problems, the AFDC framework shall also allow for dealing with exclusive active fault detection (no control objectives) and exclusive control (no fault detection objectives).

2 - Active fault detection and control problems solution

The second goal of the thesis is to derive solution to AFDC problems. The class of problems that is analyzed in the thesis generally results into complex functional optimization problems that are numerically intractable. The goal is to make use of dynamic programming that allow to decompose complex AFDC problems into smaller problems. However, employment of dynamic programming provides a numerically tractable solution for small scale problems only. Therefore, the focus will be laid also on the derivation of a numerically tractable suboptimal solution for a representative subclass of AFDC problems.

3 - Illustrative examples and applicability demonstration

Finally, the suboptimal AFDC solution will be demonstrated by means of several numerical examples that can be divided into two parts. The aim of the first part is to illustrate the key aspects of AFDC such as shape of constraints sets and objective functions using a simple scalar model.

The aim of the second part is to demonstrate applicability of AFDC and highlight some practically interesting properties of the presented AFDC framework using an application example. The application example will focus on AFDC of an Air Handling Unit (AHU) and it will cover the whole procedure of AFDC design from a model construction, through constraints and objective function definition, to a discussion of results and implementation aspects. The goal of the application example is to show that AFDC can make use of recent trends in energy systems and provide an economically efficient solution that fulfills all design requirements.

Chapter 4

General framework for active fault detection and control

A general framework for AFDC is introduced in this chapter. After the framework definition, several special cases that fit into the framework are highlighted.

4.1 Active fault detection and control framework

Introduction of AFDC framework will start with a description of AFDC topology. Two subsystems are recognized within the AFDC framework: a given subsystem S_1 and a subsystem S_2 that has to be designed, see Figure 4.1. The given subsystem S_1 includes the observed and controlled system (denoted as S). The detector or the controller can be also given and included in S_1 . All elements in S_1 represent equality constraints that have to be respected while designing S_2 . The subsystem S_2 includes the controller and the detector that have to be designed with respect to S_1 and other design requirements that are expressed in form of inequality constraints and objective function. Each component will be discussed in detail.

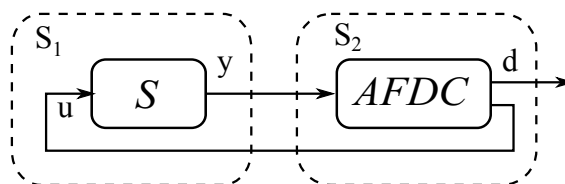

Figure 4.1: The block diagram of active detection and control.

4.1.1 Observed and controlled system

The observed and controlled system S is described by a nonlinear stochastic discrete-time state space model

$$\begin{aligned} \mathbf{x}_{k+1} &= \mathbf{f}_k(\mathbf{x}_k, \mu_k, \mathbf{u}_k, \mathbf{w}_k), & k &= 0, 1, \dots, F-1, \\ \mu_{k+1} &= \mathbf{g}_k(\mathbf{x}_k, \mu_k, \mathbf{u}_k, \mathbf{e}_k), & k &= 0, 1, \dots, F-1, \\ \mathbf{y}_k &= \mathbf{h}_k(\mathbf{x}_k, \mu_k, \mathbf{v}_k), & k &= 0, 1, \dots, F. \end{aligned} \quad (4.1)$$

The index k denotes a time step and $F \in (0, \infty)$ denotes the last time step of the finite horizon. The input and output of the system S are denoted as $\mathbf{u}_k \in \mathcal{U}_k \subseteq \mathbb{R}^{n_u}$ and $\mathbf{y}_k \in \mathbb{R}^{n_y}$, respectively. The unmeasured state $\bar{\mathbf{x}}_k = [\mathbf{x}_k^T, \mu_k^T]^T$ of the system S is composed of the vector variable $\mathbf{x}_k \in \mathbb{R}^{n_x}$ and the discrete scalar variable $\mu_k \in \mathcal{M} \subseteq \mathbb{N}$. The variable \mathbf{x}_k represents the basic part of the state $\bar{\mathbf{x}}_k$, which is usually driven by the input \mathbf{u}_k to a desirable value or a region of the state space. The variable μ_k carries information about changes or faults in the system S . It can be seen as a scalar variable indexing a mode of behavior of the system S . The initial state $\bar{\mathbf{x}}_0$ is described by a known probability density function (pdf) $p(\bar{\mathbf{x}}_0) = p(\mathbf{x}_0)p(\mu_0)$. The white noise sequences $\{\mathbf{w}_k\}$, $\{\mathbf{e}_k\}$ and $\{\mathbf{v}_k\}$ are described by known pdf's $p(\mathbf{w}_k)$, $p(\mathbf{e}_k)$ and $p(\mathbf{v}_k)$, respectively. For the sake of brevity, all noise signals are denoted as $\bar{\mathbf{w}}_k = [\mathbf{w}_k^T, \mathbf{e}_k^T, \mathbf{v}_k^T]^T$. The initial state $\bar{\mathbf{x}}_0$ and the noise sequence $\{\bar{\mathbf{w}}_k\}$ are mutually independent. The general nonlinear vector functions $\mathbf{f}_k(\mathbf{x}_k, \mu_k, \mathbf{u}_k, \mathbf{w}_k) : \mathbb{R}^{n_x} \times \mathcal{M} \times \mathbb{R}^{n_u} \times \mathbb{R}^{n_w} \mapsto \mathbb{R}^{n_x}$, $\mathbf{g}_k(\mathbf{x}_k, \mu_k, \mathbf{u}_k, \mathbf{e}_k) : \mathbb{R}^{n_x} \times \mathcal{M} \times \mathbb{R}^{n_u} \times \mathbb{R}^{n_e} \mapsto \mathcal{M}$ and $\mathbf{h}_k(\mathbf{x}_k, \mu_k, \mathbf{v}_k) : \mathbb{R}^{n_x} \times \mathcal{M} \times \mathbb{R}^{n_v} \mapsto \mathbb{R}^{n_y}$ are known. Note that the function $\mathbf{g}_k(\mathbf{x}_k, \mu_k, \mathbf{u}_k, \mathbf{e}_k)$ represents a stochastic model of faults.

4.1.2 Detector and controller

Within the general formulation the aim is to design the causal deterministic system S_2 that generates the decision d_k and the input \mathbf{u}_k based on a complete available information at each time step $k \in \mathcal{T} = \{0, 1, \dots, F\}$. All the available information from time step 0 to time step k is denoted as $\mathbf{I}_0^k = [\mathbf{y}_0^{kT}, \mathbf{u}_0^{k-1T}, d_0^{k-1T}]^T$. The notation \mathbf{z}_i^j is used for expressing the time sequence of variables or functions \mathbf{z}_k from the time step i up to the time step j . If it happens in an expression that i is greater than j , then the sequence \mathbf{z}_i^j is empty, and the corresponding variable or function is simply left out from the expression. According to this rule, the information vector for the time step $k = 0$ is defined as $\mathbf{I}_0^0 = \mathbf{I}_0 = \mathbf{y}_0$. The system S_2 can be described at each time step $k \in \mathcal{T}$ by the relation

$$\begin{bmatrix} d_k \\ \mathbf{u}_k \end{bmatrix} = \boldsymbol{\rho}_k(\mathbf{I}_0^k), \quad (4.2)$$

where $d_k \in \mathcal{M}$ is the decision providing information about the variable μ_k and $\boldsymbol{\rho}_k(\mathbf{I}_0^k) : \mathbb{R}^{(k+1) \times n_y} \times \mathcal{U}_0 \times \dots \times \mathcal{U}_{k-1} \times \mathcal{M}^k \mapsto \mathcal{M} \times \mathcal{U}_k$ is an unknown vector function. Note that the decision d_k can be regarded as a point estimate of the variable μ_k . It is assumed that the function $\boldsymbol{\rho}_k(\mathbf{I}_0^k)$ belongs to the set of competing

functions $\Gamma_k \subseteq \Gamma_k^+$, where Γ_k^+ is the set of all functions that are admissible at the time step k , i.e. functions that do not create an algebraic loop. A sequence of functions $\boldsymbol{\rho}_0^F = [\boldsymbol{\rho}_0(\mathbf{y}_0), \boldsymbol{\rho}_1(\mathbf{I}_0^1), \dots, \boldsymbol{\rho}_F(\mathbf{I}_0^F)]$ is called policy. The set of admissible policies is denoted $\Gamma^+ = \Gamma_0^+ \times \Gamma_1^+ \times \dots \times \Gamma_F^+$ and the set of competing policies is denoted $\Gamma \subseteq \Gamma^+$.

For the further analysis, it is useful to separate $\boldsymbol{\rho}_k(\mathbf{I}_0^k)$ into two parts

$$\begin{bmatrix} d_k \\ \mathbf{u}_k \end{bmatrix} = \begin{bmatrix} \boldsymbol{\gamma}_k(\mathbf{I}_0^k) \\ \boldsymbol{\delta}_k(\mathbf{I}_0^k, d_k) \end{bmatrix} = \boldsymbol{\rho}_k(\mathbf{I}_0^k), \quad (4.3)$$

where $\boldsymbol{\gamma}_k(\mathbf{I}_0^k) : \mathbb{R}^{(k+1) \times n_y} \times \mathcal{U}_0 \times \dots \times \mathcal{U}_{k-1} \times \mathcal{M}^k \mapsto \mathcal{M}$ is the detector and $\boldsymbol{\delta}_k(\mathbf{I}_0^k, d_k) : \mathbb{R}^{(k+1) \times n_y} \times \mathcal{U}_0 \times \dots \times \mathcal{U}_{k-1} \times \mathcal{M}^{k+1} \mapsto \mathcal{U}_k$ is the controller. The controller can be a function of the decision d_k that is given by the detector in the current time step. The function $\boldsymbol{\rho}_k(\mathbf{I}_0^k)$ can be partially fixed. For example, the detector $\boldsymbol{\gamma}_k(\mathbf{I}_0^k)$ can be given in advance. Then the aim is to design the controller $\boldsymbol{\delta}_k(\mathbf{I}_0^k, d_k)$ with respect to the given detector. Or vice versa, the controller can be given in advance and the aim is to design the detector only. Partially fixed $\boldsymbol{\rho}_k(\mathbf{I}_0^k)$ will be discussed in section 4.2.

4.1.3 General criterion

Similarly to the optimal stochastic control [Bar-Shalom, 1981], a suitable criterion is needed for evaluating behavior of the closed loop system. The design of the optimal system S_2 is then based on minimization of such a criterion. An additive criterion is considered in the following form

$$J(\boldsymbol{\rho}_0^F) = \mathbb{E} \left\{ \sum_{k=0}^F L_k(\mu_k, d_k, \mathbf{x}_k, \mathbf{u}_k) \right\}, \quad (4.4)$$

where $J(\boldsymbol{\rho}_0^F)$ is an objective function that express the expected cost when the policy $\boldsymbol{\rho}_0^F$ is applied. The cost function $L_k(\mu_k, d_k, \mathbf{x}_k, \mathbf{u}_k) : \mathcal{M} \times \mathcal{M} \times \mathbb{R}^{n_x} \times \mathbb{R}^{n_u} \mapsto \mathbb{R}^+$ is a non-negative real-valued function.

Remark 1 *The output \mathbf{y}_k can be used as an argument of the cost function $L_k(\mu_k, d_k, \mathbf{x}_k, \mathbf{u}_k)$ as well, however, the aim is to control the state variable \mathbf{x}_k not the noisy output \mathbf{y}_k . Therefore, the output \mathbf{y}_k is not included in the cost function.*

Two competing aims can be distinguished in AFDC problems: the detection and the control aim. The detection aim concerns the quality of the detection that can be measured, for example, by the probability of making a wrong decision. The control aim focuses on the quality of control that requires the state to follow a reference trajectory as close as possible while the control effort is not excessive. These two aims are usually in contradiction. The particular structure of the cost function that captures this contradiction will be considered in the thesis as

$$L_k(\mu_k, d_k, \mathbf{x}_k, \mathbf{u}_k) = \alpha L_k^d(\mu_k, d_k) + (1 - \alpha) L_k^c(\mathbf{x}_k, \mathbf{u}_k), \quad \alpha \in \langle 0, 1 \rangle, \quad (4.5)$$

where α is a weighting factor, $L_k^d(\mu_k, d_k) : \mathcal{M} \times \mathcal{M} \mapsto \mathbb{R}^+$ is a detection cost function and $L_k^c(\mathbf{x}_k, \mathbf{u}_k) : \mathbb{R}^{n_x} \times \mathbb{R}^{n_u} \mapsto \mathbb{R}^+$ is a control cost function. The detection objective function $L_k^d(\mu_k, d_k)$ penalizes wrong decisions. It is reasonable to require that the detection cost function $L_k^d(\mu_k, d_k)$ satisfies the inequality $L_k^d(\mu_k, \mu_k) \leq L_k^d(\mu_k, d_k)$ for all $\mu_k \in \mathcal{M}$, $d_k \in \mathcal{M}$, $d_k \neq \mu_k$ at each time step $k \in T$, and the strict inequality holds at least at one time step. The control cost function $L_k^c(\mathbf{x}_k, \mathbf{u}_k)$ is a non-negative function chosen by a designer. The detection objective function is defined as

$$J^D(\boldsymbol{\rho}_0^F) = \mathbb{E} \left\{ \sum_{k=0}^F L_k^d(\mu_k, d_k) \right\} \quad (4.6)$$

and the control objective function is defined as

$$J^C(\boldsymbol{\rho}_0^F) = \mathbb{E} \left\{ \sum_{k=0}^F L_k^c(\mathbf{x}_k, \mathbf{u}_k) \right\}. \quad (4.7)$$

4.1.4 Constraints

Two groups of constraints could be taken into account during design of the system S_2 . The first group contains the constraints that follow from design considerations and physical, logical or other restrictions imposed by the system S . Since these constraints apply at individual time steps, they will be called instantaneous. The second group comprises the constraints that are imposed exclusively by the designer to meet some detection or control aims. In contrast to the instantaneous constraints, these constraints deal with the behavior of the system S over the whole finite-time horizon and they are referred to as sum constraints. Both types of constraints are discussed in detail in the following.

Instantaneous constraints

Various types of instantaneous constraints such as linear, quadratic, second order cone or even set membership constraints can be considered [Boyd and Vandenberghe, 2004]. For the sake of simplicity, linear instantaneous constraints will be considered in the thesis. Note that linear constraints can be used to approximate any convex constraints to an arbitrary degree of accuracy. Moreover, most of the results presented in the thesis do apply for other types of constraints as well but numerical evaluation can be more demanding. The instantaneous constraints will be defined for the inputs \mathbf{u}_k and the expected states $\mathbb{E}\{\mathbf{x}_k | \mu_k\}$.

Although the input \mathbf{u}_k is given by a function of random variables $\boldsymbol{\delta}_k(\mathbf{I}_0^k, d_k)$, it is possible to constrain individual realizations of the input by considering only functions with an image satisfying the given instantaneous constraint. Therefore, the set of admissible inputs \mathcal{U}_k can be defined using instantaneous input constraints

as

$$\mathcal{U}_k = \{\mathbf{u}_k : \mathbf{u}_k \in \mathbb{R}^{n_u}, \mathbf{S}_k^u \mathbf{u}_k \leq \mathbf{s}_k^u\}, \quad (4.8)$$

$$\mathcal{U} = \mathcal{U}_0 \times \mathcal{U}_1 \times \dots \times \mathcal{U}_{F-1}, \quad (4.9)$$

where the matrix $\mathbf{S}_k^u \in \mathbb{R}^{n_s \times n_u}$ and the vector $\mathbf{s}_k^u \in \mathbb{R}^{n_s}$ are given. Note that the inequality is taken element-wise over the vectors $\mathbf{S}_k^u \mathbf{u}_k$ and \mathbf{s}_k^u .

In contrast to the input \mathbf{u}_k , the state \mathbf{x}_k is an internal random variable of the system S and it cannot be constrained directly. To overcome this issue, three approaches were proposed in literature, namely expectation constraints, chance constraints and worst case constraints [Prékopa, 2010]. In the worst case constraints formulations, disturbances are assumed to be bounded. Therefore, the worst case constraints fit into the robust approach. Within the stochastic approach to AFDC, the expectation and the chance constraints can be used. The expectation constraints allow for constraining the expected value only. The chance constraints allow for expressing required probability of constraints fulfillment. For the sake of simplicity, the expectation constraints are considered in the AFDC framework. The set of admissible expected states is defined for each time step and it is conditioned by μ_k

$$\mathcal{X}_{k|\mu_k} = \{E\{\mathbf{x}_k|\mu_k\} : \mathbf{S}_{k|\mu_k}^x E\{\mathbf{x}_k|\mu_k\} \leq \mathbf{s}_{k|\mu_k}^x\}, \quad (4.10)$$

where the matrices $\mathbf{S}_{k|\mu_k}^x \in \mathbb{R}^{n_r \times n_x}$ and vectors $\mathbf{s}_{k|\mu_k}^x \in \mathbb{R}^{n_r}$ are given. This formulation allows to define state expectation constraints for each model separately i.e. different state expectation constraints can be defined for fault free and for faulty operation.

Sum constraints

The objective functions $J^D(\boldsymbol{\rho}_0^F)$ and $J^C(\boldsymbol{\rho}_0^F)$ can be simultaneously minimized in order to obtain the optimal controller. However, a less strict requirements can be imposed for those two aims in some applications. Instead of requiring to minimize both objective functions it may be sufficient to keep their values below a prescribed upper limit value. Therefore, two sum constraints on detection and control objective functions can be considered

$$J^D(\boldsymbol{\rho}_0^F) \leq J_{\max}^D, \quad (4.11)$$

$$J^C(\boldsymbol{\rho}_0^F) \leq J_{\max}^C, \quad (4.12)$$

where $J_{\max}^D \in \{\mathbb{R}, \infty\}$ and $J_{\max}^C \in \{\mathbb{R}, \infty\}$ are maximal acceptable levels of the detection and control objective functions, respectively.

4.1.5 Problem formulation

The aim is to find a policy $\boldsymbol{\rho}_0^{F*}$ that minimizes the given objective function with respect to all constraints and the system S_1

$$\boldsymbol{\rho}_0^{F*} = \arg \min_{\boldsymbol{\rho}_0^F \in \Gamma} \mathbb{E} \left\{ \sum_{k=0}^F \alpha L_k^d(\mu_k, d_k) + (1 - \alpha) L_k^c(\mathbf{x}_k, \mathbf{u}_k) \right\}, \quad (4.13)$$

subject to

$$\mathbf{u}_0^{F-1} \in \mathcal{U}, \quad \text{input instantaneous constraints} \quad (4.14)$$

$$\mathbb{E}\{\mathbf{x}_k | \mu_k\} \in \mathcal{X}_{k|\mu_k}, \mu_k \in \mathcal{M} \quad \text{state expectation instantaneous constraints} \quad (4.15)$$

$$J^D(\boldsymbol{\rho}_0^F) \leq J_{\max}^D, \quad \text{detection sum constraints} \quad (4.16)$$

$$J^C(\boldsymbol{\rho}_0^F) \leq J_{\max}^C, \quad \text{control sum constraints} \quad (4.17)$$

$$\mathbf{x}_{k+1} = \mathbf{f}_k(\mathbf{x}_k, \mu_k, \mathbf{u}_k, \mathbf{w}_k), \quad \text{system } S_1 \quad (4.18)$$

$$\mu_{k+1} = \mathbf{g}_k(\mathbf{x}_k, \mu_k, \mathbf{u}_k, \mathbf{e}_k),$$

$$\mathbf{y}_k = \mathbf{h}_k(\mathbf{x}_k, \mu_k, \mathbf{v}_k),$$

$$\mathbf{x}_0 \sim p(\mathbf{x}_0), \mu_0 \sim p(\mu_0). \quad \text{initial conditions} \quad (4.19)$$

Remark 2 *The general problem formulation (4.13)-(4.19) incorporates the detection as well as the control sum constraints. Any of the sum constraints can be left out by setting its maximal acceptable level J_{\max}^D or J_{\max}^C to infinity.*

Remark 3 *The instantaneous constraints can be left out from the general formulation (4.13)-(4.19) as well by setting $\mathcal{U} = \mathbb{R}^{n_u \times F}$ and $\mathcal{X}_{k|\mu_k} = \mathbb{R}^{n_x} \times \mathcal{M}$.*

4.2 Special cases

The AFDC framework covers a wide range of special cases that can be derived from the formulation (4.13)-(4.19). In this section, several important variants of the general framework are pointed out. Two possible distinctions are discussed separately. The first distinction arises when the structure of S_2 is partially fixed. The second distinction focuses on the different usage of the detection and the control objective. These two possible distinctions are combined at the end of the chapter, where nine special cases are defined.

Detector and controller

Design of the function $\boldsymbol{\rho}_k(\mathbf{I}_0^k)$ can be restricted by structural requirements. Namely, the detector or the controller can be given in advance. Then the goal is to design only the remaining part of $\boldsymbol{\rho}_k(\mathbf{I}_0^k)$. There are three important combinations that can be investigated within the AFDC framework. For sake of completeness one additional combination that can be interpreted as a feasibility study will be mentioned as well, however, this combination is out of the scope of the AFDC framework.

- **No structural constraints** The goal is to design an active fault detector and controller

$$\boldsymbol{\rho}_0^{F*} = \arg \min_{\boldsymbol{\rho}_0^F \in \Gamma} J(\boldsymbol{\rho}_0^F) \quad (4.20)$$

$$\text{subject to (4.14)- (4.19).} \quad (4.21)$$

- **Given detector** The goal is to design a controller

$$\boldsymbol{\delta}_0^{F*} = \arg \min_{\boldsymbol{\delta}_0^F \in \Gamma} J(\boldsymbol{\rho}_0^F) \quad (4.22)$$

$$\text{subject to (4.14)- (4.19) and the given detector } \boldsymbol{\gamma}_0^F. \quad (4.23)$$

- **Given controller** The goal is to design an active fault detector

$$\boldsymbol{\gamma}_0^{F*} = \arg \min_{\boldsymbol{\gamma}_0^F \in \Gamma} J(\boldsymbol{\rho}_0^F) \quad (4.24)$$

$$\text{subject to (4.14)- (4.19) and given the given controller } \boldsymbol{\delta}_0^F. \quad (4.25)$$

- **Given detector and controller** The goal is to decide if

the given detector $\boldsymbol{\gamma}_0^F$ and the given controller $\boldsymbol{\delta}_0^F$ do satisfy (4.14)- (4.19).

The topology of all four combinations is depicted in Figure 4.2. In case of no structural constraints, the goal is to design the whole system S_2 without any additional structural constraints on the designed system. In some situations, the detector is given in advance, and it has to be taken into account while designing the controller $\boldsymbol{\delta}_k(\mathbf{I}_0^k, d_k)$. Such a situation typically arises when the detector has been already hardwired into the system, for example, in case of hardware redundancy fault detection. Then the goal can be to influence the input signal in order to improve performance of the hardwired detector. Another scenario is when a suboptimal detector is used because the optimal one is too complex to be implemented. When the controller is given, the goal is to design the detector $\boldsymbol{\gamma}_k(\mathbf{I}_0^k)$. Contrary to the given detector where the decision d_k is a function of \mathbf{I}_0^k , in the case of the given controller the input \mathbf{u}_k is generally a function of \mathbf{I}_0^k and also the current decision d_k . In other words, the decision of the detector d_k can influence the input in the current time step \mathbf{u}_k . A multimodel controller consisting of several controllers that are switched according to the decision d_k can be considered as a typical example of such a situation. When the detector and the controller are given, then there is nothing to be designed, however, feasibility of the given problem can be validated.

Criterion and sum constraints

It was pointed out in [Široký et al., 2011b], that expressing the detection or the control aim as a constraint rather than including it into an objective function makes

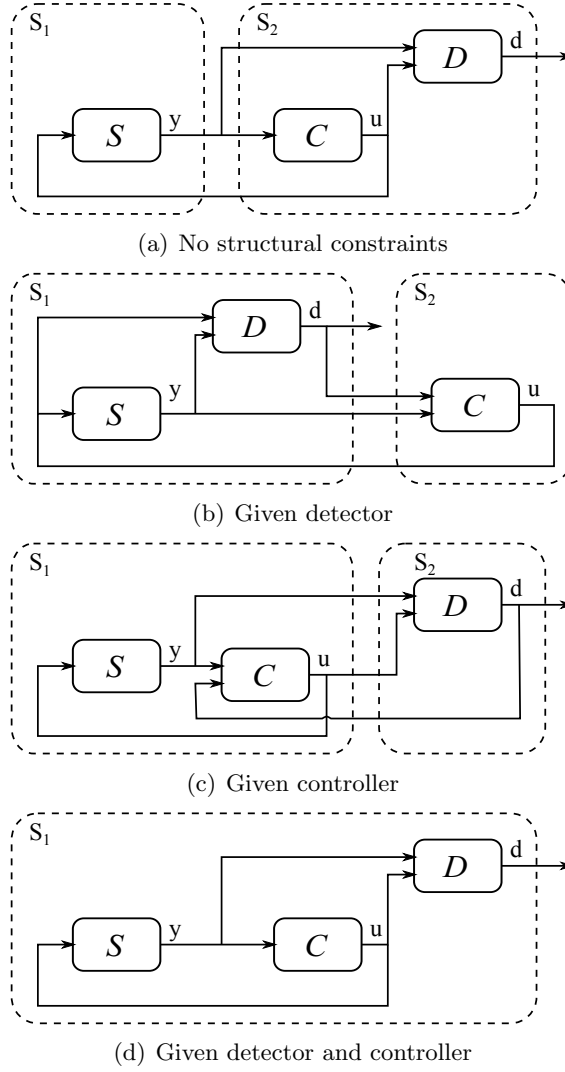

Figure 4.2: Topology of AFDC with different structural constraints.

it possible to guarantee the required quality by keeping one of the objective functions under a prescribed upper limit value while the other one is minimized. Different problem formulations can be derived by varying the weighting parameter α and the maximal acceptable levels of the detection and control sum constraints. Specifically, the following five formulations of AFDC are of interest

- **Prob^C** The goal is the minimization of the control objective function with no sum constraints.

$$\boldsymbol{\rho}_0^{F*} = \arg \min_{\boldsymbol{\rho}_0^F \in \Gamma} J^C(\boldsymbol{\rho}_0^F) \quad (4.26)$$

$$\text{subject to (4.1), } \mathbf{u}_0^{F-1} \in \mathcal{U}, \mathbb{E}\{\mathbf{x}_k | \mu_k\} \in \mathcal{X}_{k|\mu_k}, \mu_k \in \mathcal{M}, k \in \mathcal{T}. \quad (4.27)$$

- **Prob_D^C** The goal is minimization of the control objective function with respect to the detection sum constraint.

$$\boldsymbol{\rho}_0^{F*} = \arg \min_{\boldsymbol{\rho}_0^F \in \Gamma} J^C(\boldsymbol{\rho}_0^F) \quad (4.28)$$

$$\text{subject to (4.1), } \mathbf{u}_0^{F-1} \in \mathcal{U}, \mathbb{E}\{\mathbf{x}_k | \mu_k\} \in \mathcal{X}_{k|\mu_k}, \mu_k \in \mathcal{M}, k \in \mathcal{T}, J^D(\boldsymbol{\rho}_0^F) \leq J_{\max}^D. \quad (4.29)$$

- **Prob^{CD}** The goal is minimization of the objective function expressing the trade-off between control and detection with no sum constraints.

$$\boldsymbol{\rho}_0^{F*} = \arg \min_{\boldsymbol{\rho}_0^F \in \Gamma} \alpha J^D(\boldsymbol{\rho}_0^F) + (1 - \alpha) J^C(\boldsymbol{\rho}_0^F) \quad (4.30)$$

$$\text{subject to (4.1), } \mathbf{u}_0^{F-1} \in \mathcal{U}, \mathbb{E}\{\mathbf{x}_k | \mu_k\} \in \mathcal{X}_{k|\mu_k}, \mu_k \in \mathcal{M}, k \in \mathcal{T}. \quad (4.31)$$

- **Prob_C^D** The goal is minimization of the detection objective function with respect to the control sum constraint.

$$\boldsymbol{\rho}_0^{F*} = \arg \min_{\boldsymbol{\rho}_0^F \in \Gamma} J^D(\boldsymbol{\rho}_0^F) \quad (4.32)$$

$$\text{subject to (4.1), } \mathbf{u}_0^{F-1} \in \mathcal{U}, \mathbb{E}\{\mathbf{x}_k | \mu_k\} \in \mathcal{X}_{k|\mu_k}, \mu_k \in \mathcal{M}, k \in \mathcal{T}, J^C(\boldsymbol{\rho}_0^F) \leq J_{\max}^C. \quad (4.33)$$

- **Prob^D** The goal is minimization of the detection objective function with no sum constraints.

$$\boldsymbol{\rho}_0^{F*} = \arg \min_{\boldsymbol{\rho}_0^F \in \Gamma} J^D(\boldsymbol{\rho}_0^F) \quad (4.34)$$

$$\text{subject to (4.1), } \mathbf{u}_0^{F-1} \in \mathcal{U}, \mathbb{E}\{\mathbf{x}_k | \mu_k\} \in \mathcal{X}_{k|\mu_k}, \mu_k \in \mathcal{M}, k \in \mathcal{T}. \quad (4.35)$$

These five formulations are denoted as *principal AFDC formulations* in the thesis. A summary of predefined parameters that allow to derive the principal AFDC formulations from the general formulation (4.13)-(4.19) is given in Table 4.1.

The formulations **Prob_D^C**, **Prob^{CD}** and **Prob_C^D** align with the main goal of the thesis that is AFDC, while the formulations **Prob^C** and **Prob^D** are marginal cases that outline the relationship of the proposed framework to the well known fields of optimal control and AFD. The formulation **Prob_D^C** focuses on maintaining a desired quality of detection while minimizing the control objective function. The formulation **Prob_C^D** focuses on attaining the best possible detection quality while keeping the control objective function below a prescribed limit value. Finally, the formulation **Prob^{CD}** focuses on minimizing the weighted sum of both objective functions which can be useful when the detection and control objective functions

Table 4.1: Principal AFDC formulations parameters. Symbol 'n/a' denotes the parameters that are not determined by problem formulation and has to be chosen by a designer and ∞ indicates that the particular sum constraint is not applied.

	α	J_{\max}^D	J_{\max}^C
Prob^C	0	∞	∞
Prob_D^C	0	n/a	∞
Prob^{CD}	n/a	∞	∞
Prob_C^D	1	∞	n/a
Prob^D	1	∞	∞

express the same quantity (e.g. monetary control cost and cost of unhandled failures and false alarms).

It was shown that reasonable special cases of AFDC can be derived based on two different criteria: partially fixed structure of $\rho_k(\mathbf{I}_0^k)$ and definition of sum constraints. These two criteria can be combined and many unique special cases can be defined. In the thesis, special attention will be focused on all principal formulations in combinations with a given detector. Analysis of these formulations allows for comparing active and passive approach to fault detection. The formulation **Prob^C** with a given detector can be interpreted as an example of passive detection. The input signal is designed regardless to detection aims, however, fault detection is performed by the given fault detector. All other principal formulations with a given detector can be seen as examples of active approach to fault detection.

4.3 Discussion

The general AFDC framework was introduced. The AFDC framework allows expressing various AFDC design requirements. The detection and the control aim can be expressed as a part of the cost function or as a sum constraint. The expected state trajectory as well as the input trajectory can be also constrained. Moreover, the AFDC framework allows handling of partially predefined structure of AFDC system, such as given detector or controller. It is advantageous, for example, in case of retrofitting of an existing controller or passive detector. The proposed AFDC framework then allows for adapting the AFDC formulation to the existing system and make advantage of all properties of AFDC.

Some of the preceding works in the field of stochastic AFD and AFDC can be identified in the proposed AFDC framework, see Table 4.2. This table is partially taken from [Šimandl et al., 2011], where nine special cases of AFDC were introduced. However, no sum constraints were considered in [Šimandl et al., 2011]. The AFD formulation defined in [Blackmore and Williams, 2006] can be interpreted as **Prob^D** with input as well as state expectation constraints. In contrast to the AFDC framework introduced in the thesis the formulation proposed in [Blackmore

and Williams, 2006] does not allow to handle the control aim. The control aim was not considered as a part of objective function nor as a sum constraint. Four formulations introduced in [Šimandl and Punčochář, 2009] can be interpreted as **Prob^C**, **Prob^{CD}** and **Prob^D** without structural constraints and **Prob^D** with the given controller. Only the input constraints were taken into account in [Šimandl and Punčochář, 2009], no state expectation constraints nor sum constraints were considered.

Table 4.2: Summary of AFDC special cases and their realition to the previously published AFDC papers. In the first row, there are cases where the goal is to design S_2 without any limitations. In the second row, there are cases with the given detector. The detector is denoted as passive in the first column because the given detector does not influence the input signal design at all. In the third column of the second row, the only purpose of S_2 is to minimize the detection objective function. Therefore, S_2 is called generator instead of controller. The same terminology is used in the third row of the third column, where the detector is given. Finally, S_2 is called decision generator in the first column of the third row because the decision d_k serves only for improvement of the control objective. For details regarding each special case, see the references in the table.

	Control aim Prob^C	Detection and control aims Prob^C_D, Prob^{CD}, Prob^D_C	Detection aim Prob^D
No structural constraints	Active controller [Šimandl and Punčochář, 2009] [Bertsekas, 2005a] [Šimandl et al., 2011]	Active detector and active controller [Šimandl and Punčochář, 2009] [Šimandl et al., 2011]	Active detector [Šimandl and Punčochář, 2009] [Blackmore and Williams, 2006] [Šimandl et al., 2011]
Given detector	Active controller and a passive detector [Široký et al., 2011b] [Šimandl et al., 2011]	Active controller for a given detector [Široký et al., 2011b] [Široký et al., 2012] [Šimandl et al., 2011]	Active generator for a given detector [Široký et al., 2011b] [Šimandl et al., 2011]
Given controller	Active decision generator for a given controller [Punčochář et al., 2010] [Šimandl et al., 2011]	Active detector for a given controller [Šimandl et al., 2011]	Active detector for a given generator [Šimandl and Punčochář, 2009] [Šimandl et al., 2011]

Chapter 5

Optimal solution

The vast majority of problems that can be defined within the presented AFDC framework represent a complex functional optimization problem. There is no general technique how to obtain the optimal solution for this class of problems. There are some AFDC formulations that can be easily solved such as **Prob^C** with linear Gaussian system, no constraints and quadratic control cost that is known as the linear quadratic Gaussian control problem [Rawlings and Mayne, 2009]. In cases of some AFDC problems, it is possible to use dynamic programming and break the complex optimization problem into simpler sub-problems using the backward recursion [Bertsekas, 2005a]. However, presence of the state expectation and sum constraints defined in the AFDC framework causes that the optimal solution cannot be, in general, obtained by the backward recursion. In this chapter, the optimal solution to AFDC problems based on dynamic programming is presented first, then the complications related to the state expectation and sum constraints are discussed.

The AFDC problems that can be solved by dynamic programming

Dynamic programming breaks the original problem into smaller sub-problems. Richard E. Bellman's principle of optimality describes how to do this: An optimal policy has the property that whatever the initial state and initial decision are, the remaining decisions must constitute an optimal policy with regard to the state resulting from the first decision [Bellman, 1957].

Dynamic programming can be used for solving the AFDC problems that do not have any sum constraints nor state expectation constraints. The set of accessible inputs \mathcal{U} can be a strict subset of $\mathbb{R}^{n_u \times F}$, i.e. the inputs \mathbf{u}_k can be constrained. The optimal policy for this class of AFDC problems can be found by solving the backward recursive equation

$$V^*_k(\mathbf{y}_0^k, \mathbf{u}_0^{k-1}) = \min_{\substack{d_k \in \mathcal{M} \\ \mathbf{u}_k \in \mathcal{U}_k}} \mathbb{E} \{ L_k(\mu_k, d_k, \mathbf{x}_k, \mathbf{u}_k) + V^*_{k+1}(\mathbf{y}_0^{k+1}, \mathbf{u}_0^k) \mid \mathbf{y}_0^k, \mathbf{u}_0^k, d_k \} , \quad (5.1)$$

where $k = F, F - 1, \dots, 0$. The Bellman function $V^*_k(\mathbf{y}_0^k, \mathbf{u}_0^{k-1})$ is the minimal expected cost that will be incurred from the time step k up to the final

time step F given the information $[\mathbf{y}_0^k, \mathbf{u}_0^{k-1}]$. The function $V^*_k(\mathbf{y}_0^k, \mathbf{u}_0^{k-1})$ is also called cost-to-go function. The initial condition for the backward recursive equation (5.1) is $V^*_{F+1} = 0$. An optimal policy $\boldsymbol{\rho}_0^{F*}$ is obtained by first minimizing $V^*_F(\mathbf{y}_0^F, \mathbf{u}_0^{F-1})$ for every possible value of $[\mathbf{y}_0^F, \mathbf{u}_0^{F-1}]$ to obtain $\boldsymbol{\rho}_F^*$. Simultaneously, $V^*_F(\mathbf{y}_0^F, \mathbf{u}_0^{F-1})$ is computed and used in computation of $V^*_{F-1}(\mathbf{y}_0^{F-1}, \mathbf{u}_0^{F-2})$ via minimization in (5.1), which is carried out for every possible value of $[\mathbf{y}_0^{F-1}, \mathbf{u}_0^{F-2}]$. This is done iteratively until $V^*_0(\mathbf{y}_0)$ is computed.

The backward recursive equation (5.1) can be rewritten as follows

$$V^*_k(\mathbf{y}_0^k, \mathbf{u}_0^{k-1}) = \min_{\substack{d_k \in \mathcal{M} \\ \mathbf{u}_k \in \mathcal{U}_k}} \left\{ \int \sum_{\mu_k \in \mathcal{M}} L_k(\mu_k, d_k, \mathbf{x}_k, \mathbf{u}_k) p(\mathbf{x}_k | \mathbf{y}_0^k, \mathbf{u}_0^{k-1}) P(\mu_k | \mathbf{y}_0^k, \mathbf{u}_0^{k-1}) d\mathbf{x}_k + \int V^*_{k+1}(\mathbf{y}_0^{k+1}, \mathbf{u}_0^k) p(\mathbf{y}_{k+1} | \mathbf{y}_0^k, \mathbf{u}_0^k) d\mathbf{y}_{k+1} \right\}. \quad (5.2)$$

Nonlinear filtering has to be used for obtaining the pdfs $p(\mathbf{x}_k | \mathbf{y}_0^k, \mathbf{u}_0^{k-1})$, $p(\mathbf{y}_{k+1} | \mathbf{y}_0^k, \mathbf{u}_0^k)$ and probability mass function $P(\mu_k | \mathbf{y}_0^k, \mathbf{u}_0^{k-1})$ that are needed for evaluating the conditional expectations in the backward recursive equation (5.3). Nonlinear filtering is a non-trivial task and its detailed discussion is out of the scope of the thesis. Detailed information about nonlinear filtering can be found in [Simon, 2006, Crassidis and Junkins, 2011, Šimandl and Duník, 2009, Šimandl et al., 2006]. If the monitored system is linear and Gaussian then a bank of Kalman filters can be used. However, the amount of filters that are needed grows exponentially in time. Each sequence of models μ_0^k requires a corresponding sequence of Kalman filters. Techniques of merging or pruning can be used for reduction of the number of analyzed sequences [Boers and Driessen, 2005].

The computational requirements of dynamic programming are usually overwhelming. The number of state combinations grows exponentially in time. This problem arises not only in automatic control but also in artificial intelligence, economics, medicine, transportation and many other areas. Richard E. Bellman named this phenomena "curse of dimensionality" [Bellman, 1957]. Optimal solutions can only be computed for special cases such as **Prob^C** with linear system and quadratic cost function (see [Bertsekas, 2005a]) or for small-scale problems as illustrated by the following example.

Example 5.3 The goal of the example is to demonstrate derivation of the optimal solution of a particular AFDC problem. The problem to be solved can be described as **Prob^D** without sum and state expectation constraints. Prediction horizon is two steps $F = 1$.

The initial condition of the Bellman equation is $V_2^* = 0$. The optimal input and decision at time step 1 are given by the following minimization

$$V_1^*(\mathbf{y}_0^1, \mathbf{u}_0) = \min_{\substack{\mathbf{u}_1 \in \mathcal{U}_1 \\ d_1 \in \mathcal{M}}} E \{ L_1^d(\mu_1, d_1) + V_2^* | \mathbf{y}_0^1, \mathbf{u}_0^1, d_1 \} = \min_{d_1 \in \mathcal{M}} E \{ L_1^d(\mu_1, d_1) | \mathbf{y}_0^1, \mathbf{u}_0^1, d_1 \}. \quad (5.4)$$

The decision d_1 has to minimize the expected value of $L_1^d(\mu_1, d_1)$, the input \mathbf{u}_1 does not affect criterion value and can be chosen arbitrary

$$\gamma_1(\mathbf{I}_0^1) = \arg \min_{d_1 \in \mathcal{M}} E \{ L_1^d(\mu_1, d_1) | \mathbf{y}_0^1, \mathbf{u}_0, d_1 \}, \quad (5.5)$$

$$\delta_1(\mathbf{I}_0^1, d_1) = \text{any } \mathbf{u}_1 \in \mathcal{U}_1. \quad (5.6)$$

At time step 0, the Bellman equation has the following form

$$V_0^*(\mathbf{y}_0) = \min_{\substack{\mathbf{u}_0 \in \mathcal{U}_0 \\ d_0 \in \mathcal{M}}} E \{ L_0^d(\mu_0, d_0) + V_1^*(\mathbf{y}_0^1, \mathbf{u}_0) | \mathbf{y}_0, \mathbf{u}_0, d_0 \} = \quad (5.7)$$

$$\min_{\substack{\mathbf{u}_0 \in \mathcal{U}_0 \\ d_0 \in \mathcal{M}}} E \left\{ L_0^d(\mu_0, d_0) + \min_{d_1 \in \mathcal{M}} E \{ L_1^d(\mu_1, d_1) | \mathbf{y}_0^1, \mathbf{u}_0^1, d_1 \} | \mathbf{y}_0, \mathbf{u}_0, d_0 \right\}. \quad (5.8)$$

For each \mathbf{u}_0 , the cost-to-go $V_1^*(\mathbf{y}_0^1, \mathbf{u}_0)$ has to be evaluated with respect to the probability of measurement y_1 . The decision d_k has to minimize cost $L_0^d(\mu_0, d_0)$ only because it does not affect any further cost. At time step 0, $\rho_0(\mathbf{y}_0)$ is given as follows

$$\gamma_0(\mathbf{y}_0) = \arg \min_{d_0 \in \mathcal{M}} E \{ L_0^d(\mu_0, d_0) | \mathbf{y}_0, d_0 \}, \quad (5.9)$$

$$\delta_0(\mathbf{y}_0, d_0) = \arg \min_{\mathbf{u}_0 \in \mathcal{U}_0} E \left\{ \min_{d_1 \in \mathcal{M}} E \{ L_1^d(\mu_1, d_1) | \mathbf{y}_0^1, \mathbf{u}_0^1, d_1 \} | \mathbf{y}_0, \mathbf{u}_0, d_0 \right\}. \quad (5.10)$$

The optimal policy ρ_0^F is given by (5.9), (5.10), (5.5) and 5.6. It can be seen that the policy is given by minimization of the expected value of detection costs that are conditioned by $\mathbf{u}_0, \mathbf{y}_0, \mathbf{y}_1$ and d_1 . Computational requirements depend on the particular model structure and the cost functions $L_1^d(\mu_1, d_1)$ and $L_0^d(\mu_0, d_0)$, however, the minimization shall be numerically tractable thanks to a low complexity of the optimization problem.

The AFDC problems that cannot be solved by dynamic programming

The complications arise when state expectation or sum constraints are included in the AFDC problem formulation. The fulfillment of further instantaneous state expectation constraints and sum constraints has to be taken into account. A decision d_k and an input \mathbf{u}_k that does not violate any constraints applied at the current time step ($\mathbf{u}_k \in \mathcal{U}_k, d_k \in \mathcal{M}$) can cause that some of further instantaneous expectation state constraints or sum constraints cannot be fulfilled. For example, the selected input $\mathbf{u}_k \in \mathcal{U}_k$ can cause such an increase in the control cost that there is no policy $[\rho_{k+1}, \rho_{k+2}, \dots, \rho_F]$ that can guarantee fulfillment of the sum constraints. The admissible policy has to guarantee fulfillment of all constraints that are applied to further states, inputs and decisions.

The standard formulation of stochastic optimal control [Bertsekas, 2005a] as-

sumes that the set of all competing policies Γ and the set of all admissible policies Γ^+ are identical and the optimal controller is found using the CL IPS by solving the backward recursive equation that relies on the principle of optimality [Bertsekas, 2005a]. However, it was pointed out in [Žampa et al., 2004] that if the set of competing policies is a strict subset of all admissible policies, it may not be possible to resolve the backward recursive equation at all time steps, i.e., it may happen that the set of competing policies does not contain the policy that is optimal for all past input-output data. This does not mean that there is no optimal policy $\rho_0^{F^*}$, however, the problem cannot be separated and solved by the backward recursive equation that uses only past input-output data regardless of past functions.

Although the set of competing policies Γ is not constrained explicitly in any of the presented formulations, the instantaneous expectation state and the sum constraints restrict the set of competing policies Γ implicitly. The set Γ can be specified as a set that contains all admissible policies $\rho_0^F \in \Gamma^+$ except those that result in violation of the instantaneous expectation state constraints or the sum constraints. An explicit description of the set Γ is extremely difficult to obtain.

Remark 4 *The AFDC problems with state expectation and sum constraints can be interpreted as multistage stochastic programming problems, where various forms of stochastic constraints are considered [Dupačová and Sladký, 2002, Shapiro and Philpott, 2007]. This interpretation, however, does not refer to any general technique that can be used for derivation of the optimal solution of AFDC problems.*

Chapter 6

Suboptimal solution

It was shown, that the optimal solution of AFDC can be obtained only for a specific subclass of AFDC problems. Most of the AFDC problems have to be solved by some approximation technique that can provide a suitable suboptimal solution. The goal of this chapter is to shortly introduce basic concepts of approximate dynamic programming and to demonstrate design of a suboptimal solution.

6.1 Approximate dynamic programming

Computational demands of many dynamic programming problems are overwhelming due to the “curse of dimensionality”. Even the dramatic speed up of computers that was achieved during the last decades did not change the fact that problems such as AFDC problems remain computationally intractable. Nevertheless, a suboptimal solution can be usually computed using techniques denoted as approximate dynamic programming¹. There is no general suggestion which of the approximate techniques is the best. Properties of the specific problem at hand have to be taken into consideration when selecting a convenient dynamic programming approximation. In this chapter, three basic concepts will be introduced. For more information on approximate dynamic programming see [Powell, 2007, Bertsekas, 2005a, Bertsekas, 2005b].

6.1.1 Rollout algorithm

Rollout algorithm is a specific type of cost-to-go approximations within the context of limited lookahead methods [Bertsekas, 2005a]. When one step lookahead method is applied, input and decision are given by the following minimization

$$\min_{\substack{d_k \in \mathcal{M} \\ \mathbf{u}_k \in \mathcal{U}_k}} \mathbb{E} \{ L_k(\mu_k, d_k, \mathbf{x}_k, \mathbf{u}_k) + \tilde{V}_{k+1}(\mathbf{y}_0^{k+1}, \mathbf{u}_0^k) \mid \mathbf{y}_0^k, \mathbf{u}_0^k, d_k \}, \quad (6.1)$$

where $\tilde{V}_{k+1}(\mathbf{y}_0^{k+1}, \mathbf{u}_0^k)$ is an approximation of $V_{k+1}^*(\mathbf{y}_0^{k+1}, \mathbf{u}_0^k)$. In the rollout algorithm, the approximation $\tilde{V}_{k+1}(\mathbf{y}_0^{k+1}, \mathbf{u}_0^k)$ is based on a heuristic policy, called

¹Sometimes denoted as neuro-dynamic programming or reinforcement learning

base policy. The base policy is used for Monte Carlo simulations that estimate the cost-to-go for different inputs \mathbf{u}_k and decisions d_k . It must be possible to perform Monte Carlo simulations and calculate the rollout algorithm in real time. The computational burden can be substantial, however, it is possible to speed up the calculation of the rollout algorithm by restricting attention to a few promising inputs \mathbf{u}_k and decisions d_k . Usage of rollout algorithm for AFDC problems was presented in [Punčochář and Šimandl, 2009].

6.1.2 Restricted structure policies

Another approach is based on narrowing the focus on particular class of feedback policies $\boldsymbol{\rho}_k(\Theta_k, \mathbf{I}_0^k)$, where Θ_k denotes a set of parameters of the policy. The goal is to find feedback policy parameters Θ_0^F that minimize the objective function

$$\min_{\Theta_k} \mathbb{E} \left\{ L_k(\mu_k, d_k, \mathbf{x}_k, \mathbf{u}_k) + V_{k+1}^*(\mathbf{y}_0^{k+1}, \mathbf{u}_0^k) \mid \mathbf{y}_0^k, \mathbf{u}_0^k, d_k \right\} \Big|_{[d_k, \mathbf{u}_k]^T = \boldsymbol{\rho}_k(\Theta_k, \mathbf{I}_0^k)}, \quad (6.2)$$

where $|_{[d_k, \mathbf{u}_k]^T = \boldsymbol{\rho}_k(\Theta_k, \mathbf{I}_0^k)}$ denotes an equality constraint defined by the given policy. The cost-to-go $V_{k+1}^*(\mathbf{y}_0^{k+1}, \mathbf{u}_0^k)$ is also evaluated with respect to the given policy. Note that the optimal solution within the given class of feedback policies does not have to be the optimal solution of the original problem. Affine disturbance feedback is an example of a restricted structure feedback policy [Oldewurtel et al., 2008].

6.1.3 Open loop strategy

In problems with imperfect information such as AFDC problems defined in the thesis, the performance of the optimal policy improves when extra information is available. However, the use of this information may render the dynamic programming calculation of the optimal policy intractable. This motivates an approximation, that in part ignores the availability of extra information.

The design of the active detector and controller is formulated similarly to a stochastic optimal control problem, where the controller design can be carried out using three different assumptions on measurements availability at individual time steps [Bar-Shalom and Tse, 1974].

Open loop (OL) - this IPS assumes that only model and a priori information will be used by the active detector and controller. The output \mathbf{y}_k is not available at any time step $k = 1, \dots, F$ and the input \mathbf{u}_k is a function of the time step k only. Since no measurements are used, this IPS is considered the simplest one.

Open loop feedback (OLF) - this IPS assumes that model, a priori information and measurements received up to time step k are used by the active detector and controller at time step k . However, potential availability of future measurements is not taken into account. As available measurements are utilized, this IPS performs better or at least as good as the OL IPS.

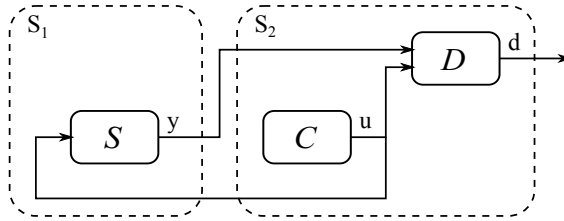

Figure 6.1: The block diagram of AFDC problems with no structural constraints and AFDC problems with a given detector when the OL IPS is used

Closed loop (CL) - this IPS assumes that model, a priori information and measurements received up to the current time step are used. Moreover, the availability of further measurements in the future is respected. As such, this IPS results into the same or better performance compared to the previous two IPSs.

All IPSs can be used within the AFDC framework and their detailed description in this context can be found, e.g., in [Punčochář and Šimandl, 2008]. Although the use of the CL IPS ensures the best performance of AFDC, its implementation is computationally prohibitive in most cases. Usage of OL IPS reduces computational demands significantly and allows a numerical solution of the AFDC problems. Although the OL IPS is the most naive strategy, it allows to find a basic controller that may be further improved. A natural extension is to employ the OLF IPS that requires to use the OL IPS at each time step of the finite horizon. A block diagram of OL IPS based AFDC is depicted in Fig. 6.1. It can be seen that the controller does not utilize any measurement y .

It was shown in [Šimandl and Punčochář, 2009] that the optimal decision d_k and the optimal input \mathbf{u}_k can be designed independently in case of AFDC formulations with no structural constraints. The optimal decision is given by minimization of the detection cost function in the current time step only, it does not influence the expected cost-to-go. It can be easily evaluated using the CL IPS. The same applies to AFDC problems with a given detector because the given detector is based, in general, on CL IPS. Therefore, the OL IPS is used for finding only the suboptimal input trajectory \mathbf{u}_0^F in case of AFDC problems with no structural constraints and AFDC problems with a given detector. Different formulation of has to be used in case of the AFDC problems with a given controller. Suboptimal solutions of the special cases with a given controller will not be discussed here. Analysis of these special cases can be found in [Punčochář et al., 2010, Šimandl and Punčochář, 2009].

The mathematical formulation of OL IPS based suboptimal solution for AFDC problems with no structural constraints and AFDC problems with a given detector reads as

$$\min_{\mathbf{u}_0^F \in \mathcal{U}} \mathbb{E} \left\{ \sum_{k=0}^F L_k | \mathbf{u}_0^F \right\}. \quad (6.3)$$

The goal is to express the objective function $E \left\{ \sum_{k=0}^F L_k | \mathbf{u}_0^F \right\}$ as a function of inputs \mathbf{u}_0^F that can be minimized using a numerical solver. The structure of the objective function determines the numerical solution tools. Preferable are simple convex functions such as linear or quadratic functions that can be efficiently minimized by various numerical solvers.

Usage of OL IPS allows for handling of instantaneous as well as sum constraints. Expected value of detection and control costs as well as the expected state trajectory can be evaluated for each combination of inputs \mathbf{u}_0^F and decisions d_0^F . It allows to exclude the set of inputs \mathbf{u}_0^F that do not fulfill the sum and instantaneous state constraints from the minimization. In the rest of the chapter, design of the OL IPS based suboptimal solution will be demonstrated.

6.2 Design of suboptimal active fault detection and control

The goal of this section is to demonstrate the design of the suboptimal solution of AFDC problems using the OL IPS. A particular structure of a monitored system and the objective functions will be chosen. In the general AFDC framework formulation, the model is described by general nonlinear vector functions (4.1). Nonlinear models significantly complicate the numerical solution of AFDC problems. Use of a nonlinear model in AFDC framework was discussed in [Široký et al., 2012]. In this chapter, only linear Gaussian time invariant systems will be considered. Moreover, it is assumed that μ_k is constant, i.e., there is no model switching. Analysis of AFDC problems with model switching can be found in [Punčochář et al., 2009, Blackmore et al., 2008]. These assumptions can be seen as too restrictive, however, many of practical applications can be described by such simplified models.

As mentioned in section 4.2, focus will be laid on AFDC problems with a given detector. Control cost function is a quadratic function. The detection cost function penalizes wrong decision in the last step of the prediction horizon only. Detailed description of the selected AFDC problems is given in the following section.

6.2.1 Problem formulation

Observed and controlled system

The AFDC problem is considered on a finite-time horizon and it is assumed that the observed and controlled system can be described by one of the following discrete-time linear Gaussian models

$$\begin{aligned} \mathbf{x}_{k+1} &= \mathbf{A}_\mu \mathbf{x}_k + \mathbf{B}_\mu \mathbf{u}_k + \mathbf{G}_\mu \mathbf{w}_k, & k &= 0, 1, \dots, F-1, \\ \mu_{k+1} &= \mu_k, & k &= 0, 1, \dots, F-1, \\ \mathbf{y}_k &= \mathbf{C}_\mu \mathbf{x}_k + \mathbf{H}_\mu \mathbf{v}_k, & k &= 0, 1, \dots, F, \end{aligned} \quad (6.4)$$

where $\mu_k \in \mathcal{M} = \{1, 2\}$ indicates the model in effect during the whole finite-time horizon. The initial state \mathbf{x}_0 has the Gaussian distribution with the known mean $\hat{\mathbf{x}}_0$ and covariance matrix Σ_{x_0} . A priori probability $P(\mu_{0|-1})$ is also known. The state

noise $\mathbf{w}_k \in \mathbb{R}^{n_w}$ and measurement noise $\mathbf{v}_k \in \mathbb{R}^{n_v}$ are mutually independent white Gaussian noises with zero means and unit covariance matrices. They are also independent of the initial state. The matrices \mathbf{A}_μ , \mathbf{B}_μ , \mathbf{G}_μ , \mathbf{C}_μ , and \mathbf{H}_μ are of appropriate dimensions. Note that matrix time index subscript is omitted since μ_k is constant. The matrix dimensions are same for all $\mu \in \mathcal{M}$.

Remark 5 *The assumption that there is no model switching significantly simplifies filtration and output prediction because the number of possible model sequences is fixed over time. Only two sequences μ_0^k are considered. Note that μ_k remains stochastic variable because it depends on the unknown initial state that is given by $P(\mu_0|-1)$.*

Given detector

Although the general formulation of AFDC allows for the detector $\gamma_k(\mathbf{I}_0^k)$ to be designed together with the controller $\delta_k(\mathbf{I}_0^k, d_k)$, a special case of the general formulation, in which the detector $\gamma_k(\mathbf{I}_0^k)$ is given in advance, is treated. A particular detector that utilizes the outputs \mathbf{y}_0^F and the inputs \mathbf{u}_0^{F-1} to generate only the final decision d_F optimal in the maximum a posteriori probability sense is considered. The detector is defined as follows

$$d_F = \gamma_F(\mathbf{I}_0^F) = \arg \max_{\mu_F \in \mathcal{M}} P(\mu_F | \mathbf{y}_0^F, \mathbf{u}_0^{F-1}), \quad (6.5)$$

where $d_F \in \mathcal{M}$ is the decision, i.e., an estimate of the true model μ_F and $P(\mu_F | \mathbf{y}_0^F, \mathbf{u}_0^{F-1})$ is the conditional probability of the model μ_F based on input-output data $[(\mathbf{y}_0^F)^T, (\mathbf{u}_0^{F-1})^T]^T$.

Detection and control cost functions

The detection aim consists of minimizing the probability that the final decision d_F of the given detector (6.5) is incorrect. Such aim is expressed by the following detection cost function

$$L_k^d(\mu_k, d_k) = \begin{cases} 1 & \text{if } k = F \wedge d_F \neq \mu_F, \\ 0 & \text{otherwise.} \end{cases} \quad (6.6)$$

The control cost function $L_k^c(\mathbf{x}_k, \mathbf{u}_k)$ is chosen to be quadratic

$$L_k^c(\mathbf{x}_k, \mathbf{u}_k) = \begin{cases} \mathbf{x}_k^T \mathbf{Q}_k \mathbf{x}_k + \mathbf{u}_k^T \mathbf{R}_k \mathbf{u}_k & \text{for } k = 0, 1, \dots, F-1, \\ \mathbf{x}_k^T \mathbf{Q}_k \mathbf{x}_k & \text{for } k = F. \end{cases} \quad (6.7)$$

with a symmetric positive semidefinite matrix \mathbf{Q}_k and a symmetric positive definite matrix \mathbf{R}_k .

6.2.2 Solution for open loop strategy

In the original problem formulation, the goal was to find an optimal policy. When the OL IPS is used, the goal is to find a sequence of inputs \mathbf{u}_0^{F-1} that minimizes the given objective function. To highlight this fact, the sequence of inputs \mathbf{u}_0^{F-1} will be used as the argument of the objective function. Note, that the last input \mathbf{u}_F is not considered because it does not change the value of the objective function. The detection and control objective functions will be expressed as functions of the input sequence. Then, nonlinear programming techniques will be used to solve the optimization problems.

For further derivations, it is useful to express the pdfs of the state and output trajectories for both models analytically. The state trajectories are described by the following conditional probability density functions

$$p(\mathbf{x}_0^F | \mu_F = i, \mathbf{u}_0^{F-1}) \sim \mathcal{N}(\hat{\mathbf{x}}_{0|i}^F, \Sigma_{x|i}), \quad (6.8)$$

$$\hat{\mathbf{x}}_{0|i}^F = \mathcal{A}_i \hat{\mathbf{x}}_0 + \mathcal{B}_i \mathbf{u}_0^{F-1}, \quad (6.9)$$

$$\Sigma_{x|i} = \mathcal{A}_i \Sigma_{x_0} \mathcal{A}_i^T + \mathcal{G}_i \mathcal{G}_i^T. \quad (6.10)$$

The output trajectories are described by the following conditional probability density functions

$$p(\mathbf{y}_0^F | \mu_F = i, \mathbf{u}_0^{F-1}) \sim \mathcal{N}(\hat{\mathbf{y}}_{0|i}^F, \Sigma_{y|i}), \quad (6.11)$$

$$\hat{\mathbf{y}}_{0|i}^F = \mathcal{C}_i \mathcal{A}_i \hat{\mathbf{x}}_0 + \mathcal{C}_i \mathcal{B}_i \mathbf{u}_0^{F-1}, \quad (6.12)$$

$$\Sigma_{y|i} = \mathcal{C}_i \mathcal{A}_i \Sigma_{x_0} \mathcal{A}_i^T \mathcal{C}_i^T + \mathcal{C}_i \mathcal{G}_i \mathcal{G}_i^T \mathcal{C}_i^T + \mathcal{H}_i \mathcal{H}_i^T, \quad (6.13)$$

where $i \in \mathcal{M}$ and the matrices $\mathcal{A}_i \in \mathbb{R}^{n_x(F+1) \times n_x}$, $\mathcal{B}_i \in \mathbb{R}^{n_x(F+1) \times n_u F}$, $\mathcal{G}_i \in \mathbb{R}^{n_x(F+1) \times n_w F}$, $\mathcal{C}_i \in \mathbb{R}^{n_y(F+1) \times n_x(F+1)}$ and $\mathcal{H}_i \in \mathbb{R}^{n_y(F+1) \times n_v(F+1)}$ are defined as follows

$$\mathcal{A}_i = \begin{pmatrix} \text{eye}(n_x) \\ \mathbf{A}_i \\ \mathbf{A}_i^2 \\ \vdots \\ \mathbf{A}_i^F \end{pmatrix}, \mathcal{B}_i = \begin{pmatrix} \mathbf{0} & \mathbf{0} & \dots & \mathbf{0} \\ \mathbf{B}_i & \mathbf{0} & \dots & \mathbf{0} \\ \mathbf{A}_i \mathbf{B}_i & \mathbf{B}_i & \dots & \mathbf{0} \\ \vdots & \vdots & \ddots & \vdots \\ \mathbf{A}_i^{F-1} \mathbf{B}_i & \mathbf{A}_i^{F-2} \mathbf{B}_i & \dots & \mathbf{B}_i \end{pmatrix}, \quad (6.14)$$

$$\mathcal{G}_i = \begin{pmatrix} \mathbf{0} & \mathbf{0} & \dots & \mathbf{0} \\ \mathbf{G}_i & \mathbf{0} & \dots & \mathbf{0} \\ \mathbf{A}_i \mathbf{G}_i & \mathbf{G}_i & \dots & \mathbf{0} \\ \vdots & \vdots & \ddots & \vdots \\ \mathbf{A}_i^{F-1} \mathbf{G}_i & \mathbf{A}_i^{F-2} \mathbf{G}_i & \dots & \mathbf{G}_i \end{pmatrix}, \mathcal{C}_i = \text{eye}(F+1) \otimes \mathbf{C}_i, \mathcal{H}_i = \text{eye}(F+1) \otimes \mathbf{H}_i, \quad (6.15)$$

where \mathbf{A}_i^p denotes p^{th} power of matrix \mathbf{A}_i , $\text{eye}(n)$ is the identity matrix of dimension n and \otimes stands for the Kronecker product.

Remark 6 The covariance matrices $\Sigma_{x|i}$ and $\Sigma_{y|i}$ do not depend on the input sequence \mathbf{u}_0^{F-1} . The mean values $\hat{\mathbf{x}}_{0|i}^F$ and $\hat{\mathbf{y}}_{0|i}^F$ are affine functions of the input sequence \mathbf{u}_0^{F-1} .

Detection objective function

Considering the detection cost function (6.6), the detection objective function can be expressed as

$$\begin{aligned} J^D(\mathbf{u}_0^{F-1}) &= \mathbb{E} \left\{ \sum_{k=0}^F L_k^d(\mu_k, d_k) \mid \mathbf{u}_0^{F-1} \right\} = \mathbb{E} \{ L_F^d(\mu_F, d_F) \mid \mathbf{u}_0^{F-1} \} = \\ &= \int \sum_{\mu_F \in \mathcal{M}} L_F^d(\mu_F, d_F) p(\mu_F, \mathbf{y}_0^F \mid \mathbf{u}_0^{F-1}) d\mathbf{y}_0^F = \\ &= \int \sum_{\mu_F \in \mathcal{M}} L_F^d(\mu_F, d_F) P(\mu_F \mid \mathbf{y}_0^F, \mathbf{u}_0^{F-1}) p(\mathbf{y}_0^F \mid \mathbf{u}_0^{F-1}) d\mathbf{y}_0^F. \end{aligned} \quad (6.16)$$

The decision d_F is determined by the given detector (6.5). The detector selects the model with the highest a posteriori probability, however, it could happen that this decision is not correct. Using (6.6), the detection objective function can be written as

$$\begin{aligned} J^D(\mathbf{u}_0^{F-1}) &= \int \sum_{\substack{\mu_F \in \mathcal{M} \\ \mu_F \neq \arg \max_i P(i \mid \mathbf{y}_0^F, \mathbf{u}_0^{F-1})}} P(\mu_F \mid \mathbf{y}_0^F, \mathbf{u}_0^{F-1}) p(\mathbf{y}_0^F \mid \mathbf{u}_0^{F-1}) d\mathbf{y}_0^F = \\ &= \int 1 - \max_{i \in \mathcal{M}} P(\mu_F = i \mid \mathbf{y}_0^F, \mathbf{u}_0^{F-1}) p(\mathbf{y}_0^F \mid \mathbf{u}_0^{F-1}) d\mathbf{y}_0^F. \end{aligned} \quad (6.17)$$

The set \mathcal{M} contains only two models, therefore the detection objective function can be simplified as follows

$$J^D(\mathbf{u}_0^{F-1}) = \int \min_{i \in \mathcal{M}} P(\mu_F = i \mid \mathbf{y}_0^F, \mathbf{u}_0^{F-1}) p(\mathbf{y}_0^F \mid \mathbf{u}_0^{F-1}) d\mathbf{y}_0^F. \quad (6.18)$$

Using Bayes' theorem

$$P(\mu_F = i \mid \mathbf{y}_0^F, \mathbf{u}_0^{F-1}) = \frac{p(\mathbf{y}_0^F \mid \mu_F = i, \mathbf{u}_0^{F-1}) P(\mu_F = i)}{p(\mathbf{y}_0^F \mid \mathbf{u}_0^{F-1})} \quad (6.19)$$

the detection objective function can be further rewritten into the form

$$\begin{aligned} J^D(\mathbf{u}_0^{F-1}) &= \int \min_{i \in \mathcal{M}} \frac{p(\mathbf{y}_0^F \mid \mu_F = i, \mathbf{u}_0^{F-1}) P(\mu_F = i)}{p(\mathbf{y}_0^F \mid \mathbf{u}_0^{F-1})} p(\mathbf{y}_0^F \mid \mathbf{u}_0^{F-1}) d\mathbf{y}_0^F = \\ &= \int \min_{i \in \mathcal{M}} p(\mathbf{y}_0^F \mid \mu_F = i, \mathbf{u}_0^{F-1}) P(\mu_F = i) d\mathbf{y}_0^F. \end{aligned} \quad (6.20)$$

Since the integral in (6.20) cannot be computed analytically and its numerical evaluation is computationally expensive, an upper bound on the detection objective function $J^D(\mathbf{u}_0^{F-1})$ is used instead. This upper bound was introduced in the context of AFD in [Blackmore and Williams, 2005] and it can be expressed as a quadratic function of the input sequence \mathbf{u}_0^{F-1} . This bound makes it possible to find a sub-optimal input sequence using numerically efficient solvers.

Using the inequality

$$\min(a, b) \leq \sqrt{ab}, \quad a \geq 0, \quad b \geq 0, \quad (6.21)$$

the detection objective function $J^D(\mathbf{u}_0^{F-1})$ can be bounded from above by $J_B^D(\mathbf{u}_0^{F-1})$ as follows

$$J^D(\mathbf{u}_0^{F-1}) \leq J_B^D(\mathbf{u}_0^{F-1}) = \sqrt{P(\mu_F = 1)P(\mu_F = 2)} \int \sqrt{p(\mathbf{y}_0^F | \mu_F = 1, \mathbf{u}_0^{F-1})p(\mathbf{y}_0^F | \mu_F = 2, \mathbf{u}_0^{F-1})} d\mathbf{y}_0^F, \quad (6.22)$$

where the integral on the right hand side represents the Bhattacharyya coefficient between two probability density functions.

Remark 7 *A more general inequality*

$$\min(a, b) \leq a^\beta b^{1-\beta}, \quad a \geq 0, \quad b \geq 0, \quad 0 \leq \beta \leq 1 \quad (6.23)$$

can be used to derive a tighter upper bound. However, the use of this inequality introduces an additional optimization variable β , that makes the optimization problem more difficult.

The expected output sequence is described by a multivariate Gaussian distribution, therefore the detection objective upper bound using (6.22) is

$$J_B^D(\mathbf{u}_0^{F-1}) = \sqrt{P(\mu_F = 1)P(\mu_F = 2)} e^{-K}, \quad (6.24)$$

$$K = \frac{1}{2} \ln \frac{|\Sigma|}{\sqrt{|\Sigma_{y|1}| |\Sigma_{y|2}|}} + \frac{1}{8} (\hat{\mathbf{y}}_{0|1}^F - \hat{\mathbf{y}}_{0|2}^F)^T \Sigma^{-1} (\hat{\mathbf{y}}_{0|1}^F - \hat{\mathbf{y}}_{0|2}^F), \quad \Sigma = \frac{\Sigma_{y|1} + \Sigma_{y|2}}{2},$$

where $|\Sigma|$ denotes the determinant of the matrix Σ . Since the covariance matrices $\Sigma_{y|i}$ do not depend on the input sequence \mathbf{u}_0^{F-1} , they can be evaluated in advance. The only term that is a function of the input sequence in (6.24) is $(\hat{\mathbf{y}}_{0|1}^F - \hat{\mathbf{y}}_{0|2}^F)^T \Sigma^{-1} (\hat{\mathbf{y}}_{0|1}^F - \hat{\mathbf{y}}_{0|2}^F)$.

When substituting (6.12) and (6.13) into (6.24), the detection objective upper bound $J_B^D(\mathbf{u}_0^{F-1})$ can be expressed in closed form as follows

$$J^D(\mathbf{u}_0^{F-1}) \leq J_B^D(\mathbf{u}_0^{F-1}) = \beta_1 e^{-\beta_2 - 0.125((\mathbf{u}_0^{F-1})^T \mathbf{H}_D \mathbf{u}_0^{F-1} + \mathbf{f}_D^T \mathbf{u}_0^{F-1} + g_D)}, \quad (6.25)$$

where

$$\beta_1 = \sqrt{P(\mu_F=1)P(\mu_F=2)}, \quad (6.26)$$

$$\beta_2 = \frac{1}{2} \ln \frac{|\Sigma|}{\sqrt{|\Sigma_{y|1}| |\Sigma_{y|2}|}}, \quad (6.27)$$

$$\mathbf{H}_D = (\mathcal{C}_1 \mathcal{B}_1 - \mathcal{C}_2 \mathcal{B}_2)^\top \Sigma^{-1} (\mathcal{C}_1 \mathcal{B}_1 - \mathcal{C}_2 \mathcal{B}_2), \quad (6.28)$$

$$\mathbf{f}_D = 2(\mathcal{C}_1 \mathcal{B}_1 - \mathcal{C}_2 \mathcal{B}_2)^\top \Sigma^{-1} (\mathcal{C}_1 \mathcal{A}_1 - \mathcal{C}_2 \mathcal{A}_2) \hat{\mathbf{x}}_0, \quad (6.29)$$

$$\mathbf{g}_D = \hat{\mathbf{x}}_0^\top (\mathcal{C}_1 \mathcal{A}_1 - \mathcal{C}_2 \mathcal{A}_2)^\top \Sigma^{-1} (\mathcal{C}_1 \mathcal{A}_1 - \mathcal{C}_2 \mathcal{A}_2) \hat{\mathbf{x}}_0 \quad (6.30)$$

can be evaluated in advance.

Remark 8 *The matrix \mathbf{H}_D is positive semidefinite.*

Control objective function

Unlike the detection objective function, the control objective function can be expressed as a quadratic function of the input sequence \mathbf{u}_0^{F-1} without any approximation. The control objective function with respect to the cost function (6.7) can be expressed in a compact form as

$$J^C(\mathbf{u}_0^{F-1}) = \mathbb{E} \left\{ (\mathbf{x}_0^F)^\top \mathcal{Q} \mathbf{x}_0^F + (\mathbf{u}_0^{F-1})^\top \mathcal{R} \mathbf{u}_0^{F-1} \mid \mathbf{u}_0^{F-1} \right\} \quad (6.31)$$

where the matrices $\mathcal{Q} \in \mathbb{R}^{n_x(F+1) \times n_x(F+1)}$ and $\mathcal{R} \in \mathbb{R}^{n_u F \times n_u F}$ are defined as follows

$$\mathcal{Q} = \begin{pmatrix} \mathbf{Q}_0 & \cdots & \mathbf{0} \\ \vdots & \ddots & \vdots \\ \mathbf{0} & \cdots & \mathbf{Q}_F \end{pmatrix}, \quad \mathcal{R} = \begin{pmatrix} \mathbf{R}_0 & \cdots & \mathbf{0} \\ \vdots & \ddots & \vdots \\ \mathbf{0} & \cdots & \mathbf{R}_{F-1} \end{pmatrix}. \quad (6.32)$$

Two features of the trace operator will be used in the following derivation. Since the quadratic form is a scalar quantity and mean value and trace are linear operators $\mathbb{E} \left\{ (\mathbf{x}_0^F)^\top \mathcal{Q} \mathbf{x}_0^F \right\} = \text{tr} \left(\mathbb{E} \left\{ (\mathbf{x}_0^F)^\top \mathcal{Q} \mathbf{x}_0^F \right\} \right) = \mathbb{E} \left\{ \text{tr} \left((\mathbf{x}_0^F)^\top \mathcal{Q} \mathbf{x}_0^F \right) \right\}$. By the cyclic property of the trace operator, $\mathbb{E} \left\{ \text{tr} \left((\mathbf{x}_0^F)^\top \mathcal{Q} \mathbf{x}_0^F \right) \right\} = \mathbb{E} \left\{ \text{tr} \left(\mathcal{Q} \mathbf{x}_0^F (\mathbf{x}_0^F)^\top \right) \right\}$

$$\begin{aligned} & \mathbb{E} \left\{ (\mathbf{x}_0^F)^\top \mathcal{Q} \mathbf{x}_0^F + (\mathbf{u}_0^{F-1})^\top \mathcal{R} \mathbf{u}_0^{F-1} \mid \mathbf{u}_0^{F-1} \right\} = \\ & \mathbb{E} \left\{ \text{tr} \left(\mathcal{Q} \mathbf{x}_0^F (\mathbf{x}_0^F)^\top \right) \mid \mathbf{u}_0^{F-1} \right\} + (\mathbf{u}_0^{F-1})^\top \mathcal{R} \mathbf{u}_0^{F-1} = \\ & \text{tr} \left(\mathcal{Q} \mathbb{E} \left\{ \mathbf{x}_0^F (\mathbf{x}_0^F)^\top \mid \mathbf{u}_0^{F-1} \right\} \right) + (\mathbf{u}_0^{F-1})^\top \mathcal{R} \mathbf{u}_0^{F-1}. \end{aligned} \quad (6.33)$$

The variable μ_F has to be taken into account while evaluating $\mathbb{E} \left\{ \mathbf{x}_0^F (\mathbf{x}_0^F)^\top \right\}$

$$\begin{aligned} \mathbb{E} \left\{ \mathbf{x}_0^F (\mathbf{x}_0^F)^\top \mid \mathbf{u}_0^{F-1} \right\} &= \sum_{i \in \mathcal{M}} P(\mu_F = i) \mathbb{E} \left\{ \mathbf{x}_0^F (\mathbf{x}_0^F)^\top \mid \mu_F = i, \mathbf{u}_0^{F-1} \right\} = \\ & \sum_{i \in \mathcal{M}} P(\mu_F = i) \left(\hat{\mathbf{x}}_{0|i}^F (\hat{\mathbf{x}}_{0|i}^F)^\top + \Sigma_{x|i} \right). \end{aligned} \quad (6.34)$$

The control objective function can be expressed as

$$\begin{aligned}
J^C(\mathbf{u}_0^{F-1}) &= \sum_{i \in \mathcal{M}} P(\mu_F = i) \operatorname{tr} \left(\mathcal{Q} \hat{\mathbf{x}}_{0|i}^F (\hat{\mathbf{x}}_{0|i}^F)^\top + \mathcal{Q} \Sigma_{x|i} \right) + (\mathbf{u}_0^{F-1})^\top \mathcal{R} \mathbf{u}_0^{F-1} = \\
&\sum_{i \in \mathcal{M}} P(\mu_F = i) \left((\hat{\mathbf{x}}_{0|i}^F)^\top \mathcal{Q} \hat{\mathbf{x}}_{0|i}^F + \operatorname{tr} (\mathcal{Q} \Sigma_{x|i}) \right) + (\mathbf{u}_0^{F-1})^\top \mathcal{R} \mathbf{u}_0^{F-1} = \\
&\sum_{i \in \mathcal{M}} P(\mu_F = i) \left((\mathcal{A}_i \hat{\mathbf{x}}_0 + \mathcal{B}_i \mathbf{u}_0^{F-1})^\top \mathcal{Q} (\mathcal{A}_i \hat{\mathbf{x}}_0 + \mathcal{B}_i \mathbf{u}_0^{F-1}) + \operatorname{tr} (\mathcal{Q} \Sigma_{x|i}) \right) + \\
&(\mathbf{u}_0^{F-1})^\top \mathcal{R} \mathbf{u}_0^{F-1} = \\
&\sum_{i \in \mathcal{M}} P(\mu_F = i) \left(\hat{\mathbf{x}}_0^\top \mathcal{A}_i^\top \mathcal{Q} \mathcal{A}_i \hat{\mathbf{x}}_0 + 2 \hat{\mathbf{x}}_0^\top \mathcal{A}_i^\top \mathcal{Q} \mathcal{B}_i \mathbf{u}_0^{F-1} + (\mathbf{u}_0^{F-1})^\top \mathcal{B}_i^\top \mathcal{Q} \mathcal{B}_i \mathbf{u}_0^{F-1} + \right. \\
&\left. \operatorname{tr} (\mathcal{Q} \Sigma_{x|i}) \right) + (\mathbf{u}_0^{F-1})^\top \mathcal{R} \mathbf{u}_0^{F-1}. \tag{6.35}
\end{aligned}$$

Finally, the control objective function with respect to the cost function (6.7) can be expressed as a quadratic function of the input sequence in the following form

$$J^C(\mathbf{u}_0^{F-1}) = (\mathbf{u}_0^{F-1})^\top \mathbf{H}_C \mathbf{u}_0^{F-1} + \mathbf{f}_C^\top \mathbf{u}_0^{F-1} + g_C, \tag{6.36}$$

where

$$\mathbf{H}_C = \sum_{i \in \mathcal{M}} P(\mu_F = i) \mathcal{B}_i^\top \mathcal{Q} \mathcal{B}_i + \mathcal{R}, \tag{6.37}$$

$$\mathbf{f}_C = \sum_{i \in \mathcal{M}} P(\mu_F = i) 2 \mathcal{B}_i^\top \mathcal{Q} \mathcal{A}_i \hat{\mathbf{x}}_0, \tag{6.38}$$

$$g_C = \sum_{i \in \mathcal{M}} P(\mu_F = i) \left(\hat{\mathbf{x}}_0^\top \mathcal{A}_i^\top \mathcal{Q} \mathcal{A}_i \hat{\mathbf{x}}_0 + \operatorname{tr} (\mathcal{Q} \Sigma_{x|i}) \right) \tag{6.39}$$

Remark 9 The matrix \mathbf{H}_C is positive definite.

Suboptimal, numerically tractable AFDC formulation

The objective functions are expressed as functions of input sequences. The constrained AFDC problems can now be formulated as optimization problems where the goal is to find such input sequences \mathbf{u}_0^{F-1} that minimize the objective functions while respecting all constraints. When detection cost function (6.6) and control cost function (6.7) are considered, OL IPS suboptimal solution \mathbf{u}_0^{F-1*} based on approximation (6.22) can be computed as follows

- **Prob^C**

$$\mathbf{u}_0^{F-1*} = \arg \min_{\mathbf{u}_0^{F-1}} \left[(\mathbf{u}_0^{F-1})^\top \mathbf{H}_C \mathbf{u}_0^{F-1} + \mathbf{f}_C^\top \mathbf{u}_0^{F-1} + g_C \right] \tag{6.40}$$

subject to (6.4) and

$$\mathbf{u}_0^{F-1} \in \mathcal{U}, \hat{\mathbf{x}}_{k|\mu_k} \in \mathcal{X}_{k|\mu_k}, \mu_k \in \mathcal{M}, k \in \mathcal{T} \tag{6.41}$$

- **Prob_D^C**

$$\mathbf{u}_0^{F-1*} = \arg \min_{\mathbf{u}_0^{F-1}} \left[(\mathbf{u}_0^{F-1})^T \mathbf{H}_C \mathbf{u}_0^{F-1} + \mathbf{f}_C^T \mathbf{u}_0^{F-1} + g_C \right] \quad (6.42)$$

subject to (6.4), (6.5) and

$$\mathbf{u}_0^{F-1} \in \mathcal{U}, \hat{\mathbf{x}}_{k|\mu_k} \in \mathcal{X}_{k|\mu_k}, \mu_k \in \mathcal{M}, k \in \mathcal{T} \quad (6.43)$$

$$- [(\mathbf{u}_0^{F-1})^T \mathbf{H}_D \mathbf{u}_0^{F-1} + \mathbf{f}_D^T \mathbf{u}_0^{F-1} + g_D] \leq \bar{J}_{\max}^D, \quad (6.44)$$

$$\text{where } \bar{J}_{\max}^D = 8 \left(\ln \left(\frac{J_{\max}^D}{\beta_1} \right) + \beta_2 \right) \quad (6.45)$$

- **Prob^{CD}**

$$\mathbf{u}_0^{F-1*} = \arg \min_{\mathbf{u}_0^{F-1}} \left[\alpha \left((\mathbf{u}_0^{F-1})^T \mathbf{H}_C \mathbf{u}_0^{F-1} + \mathbf{f}_C^T \mathbf{u}_0^{F-1} + g_C \right) + \dots \right. \\ \left. (1 - \alpha) \beta_1 e^{-\beta_2 - 0.125((\mathbf{u}_0^{F-1})^T \mathbf{H}_D \mathbf{u}_0^{F-1} + \mathbf{f}_D^T \mathbf{u}_0^{F-1} + g_D)} \right] \quad (6.46)$$

subject to (6.4), (6.5) and

$$\mathbf{u}_0^{F-1} \in \mathcal{U}, \hat{\mathbf{x}}_{k|\mu_k} \in \mathcal{X}_{k|\mu_k}, \mu_k \in \mathcal{M}, k \in \mathcal{T} \quad (6.47)$$

- **Prob_C^D**

$$\mathbf{u}_0^{F-1*} = \arg \min_{\mathbf{u}_0^{F-1}} - [(\mathbf{u}_0^{F-1})^T \mathbf{H}_D \mathbf{u}_0^{F-1} + \mathbf{f}_D^T \mathbf{u}_0^{F-1} + g_D] \quad (6.48)$$

subject to (6.4), (6.5) and

$$\mathbf{u}_0^{F-1} \in \mathcal{U}, \hat{\mathbf{x}}_{k|\mu_k} \in \mathcal{X}_{k|\mu_k}, \mu_k \in \mathcal{M}, k \in \mathcal{T} \quad (6.49)$$

$$(\mathbf{u}_0^{F-1})^T \mathbf{H}_C \mathbf{u}_0^{F-1} + \mathbf{f}_C^T \mathbf{u}_0^{F-1} + g_C \leq J_{\max}^C \quad (6.50)$$

- **Prob^D**

$$\mathbf{u}_0^{F-1*} = \arg \min_{\mathbf{u}_0^{F-1}} - [(\mathbf{u}_0^{F-1})^T \mathbf{H}_D \mathbf{u}_0^{F-1} + \mathbf{f}_D^T \mathbf{u}_0^{F-1} + g_D] \quad (6.51)$$

subject to (6.4), (6.5) and

$$\mathbf{u}_0^{F-1} \in \mathcal{U}, \hat{\mathbf{x}}_{k|\mu_k} \in \mathcal{X}_{k|\mu_k}, \mu_k \in \mathcal{M}, k \in \mathcal{T} \quad (6.52)$$

The optimization problems were derived based on the following steps.

- **Prob^C** Follows directly from (6.36).

- **Prob_D^C** Using (6.22) and (6.25), the original sum constraint $J^D(\boldsymbol{\rho}_0^F) \leq J_{\max}^D$ is replaced by a more restrictive constraint $J^D(\boldsymbol{\rho}_0^F) \leq J_B^D(\mathbf{u}_0^{F-1}) \leq J_{\max}^D$,

$$\beta_1 e^{-\beta_2 - 0.125((\mathbf{u}_0^{F-1})^T \mathbf{H}_D \mathbf{u}_0^{F-1} + \mathbf{f}_D^T \mathbf{u}_0^{F-1} + g_D)} \leq J_{\max}^D, \quad (6.53)$$

$$-0.125((\mathbf{u}_0^{F-1})^T \mathbf{H}_D \mathbf{u}_0^{F-1} + \mathbf{f}_D^T \mathbf{u}_0^{F-1} + g_D) - \beta_2 \leq \ln\left(\frac{J_{\max}^D}{\beta_1}\right). \quad (6.54)$$

Note that the terms β_2 and $\ln(J_{\max}^D/\beta_1)$ do not depend on \mathbf{u}_0^{F-1} and can be precomputed.

- **Prob^{CD}** Follows directly from (6.25) and (6.36).
- **Prob_C^D, Prob^D** The logarithm is a monotonically increasing function and the value of x that minimizes $f(x)$ also minimizes $\ln(f(x))$. Therefore, the input sequence that minimizes

$$-((\mathbf{u}_0^{F-1})^T \mathbf{H}_D \mathbf{u}_0^{F-1} + \mathbf{f}_D^T \mathbf{u}_0^{F-1} + g_D) \quad (6.55)$$

minimizes $J_B^D(\mathbf{u}_0^{F-1})$ as well.

Remark 10 *If there are no instantaneous constraints, the problems **Prob_D^C** and **Prob_C^D** are strongly dual [Boyd and Vandenberghe, 2004] and can readily be solved.*

Remark 11 *The formulations **Prob^C** does not on the detection objective function and Bhattacharyya upper bound is not used. Therefore, the **Prob^C** OL solution is the optimal **Prob^C** OL solution. All the other principal formulation OL solutions are suboptimal OL solutions.*

Remark 12 *The obtained results are based on the following two strong assumptions. Only two models are considered and the model in action does not change during the whole finite horizon. If these assumptions are relaxed, the upper bound on the detection objective becomes a more complicated function as discussed, e.g., in [Blackmore et al., 2008].*

Numerical solution

The resulting optimization problems are in general non-convex and they are therefore not possible to solve using “standard tools” as linear, quadratic or semidefinite programming solvers, which are commonly used in areas like model predictive control (MPC) for linear systems, [Camacho and Bordons, 2004, Rawlings and Mayne, 2009]. In this section it is described how these non-convex optimization problems can be solved numerically.

The approach chosen in this work is to use a global optimization routine `bmibnb` in the freely available MATLAB toolbox YALMIP, [Löfberg, 2004]. This routine implements a spatial branch and bound routine similar to the one introduced in [McCormick, 1976] for bilinear non-convex optimization problems. The main idea in

the algorithm is to compute convex envelopes that work as a convex outer approximations of the nonlinear functions. During the branch and bound process, better and better outer approximations are computed and these are used to compute lower bounds on the optimal objective function value. In the spirit of branch and bound, also upper bounds on the optimal objective function value are computed, and these are used to prune the branch and bound search tree. In this work, the lower bounds are computed using CPLEX, [CPLEX's webpage,], and the upper bounds using SNOPT, [SNOPT's webpage,].

Since this solution strategy is based on non-convex global optimization, the computational performance cannot in general be expected to be tractable. The `bmibnb` solver is very suitable for the experiments performed in this work. In a practical implementation, some relaxed version of the problems are more tractable to solve, especially if the procedure is to be performed in real-time. Some special cases, however, can be solved by less general solvers. Namely, the special case **Prob^C** can be easily solved by a quadratic convex solver.

Discussion

A numerically tractable solution for an important subclass of linear AFDC problems with Gaussian uncertainty was derived using OL IPS. It was shown, that each of five principal AFDC formulations can be formulated as an optimization problem where all objectives and constraints are expressed as a function of inputs \mathbf{u}_0^{F-1} . In case of **Prob^C**, **Prob_D^C**, **Prob_C^D** and **Prob^D**, the objective function is a quadratic function. The selected approach is analogous to the MPC approach that is widely used in practice. During the eighties of the last century, MPC became popular in process industries such as chemical plants and oil refineries. The formulation **Prob^C** can be interpreted as an elementary MPC problem that can be efficiently solved by quadratic programming solvers [Boyd and Vandenberghe, 2004]. All other formulations do result in constrained non-convex optimization problems due to presence of the detection aim. A numerically tractable solution for an important subclass of linear AFDC problems with Gaussian uncertainty was derived using OL IPS. It was shown, that each of five principal AFDC formulations can be formulated as an optimization problem where all objectives and constraints are expressed as a function of inputs \mathbf{u}_0^{F-1} . In case of **Prob^C**, **Prob_D^C**, **Prob_C^D** and **Prob^D**, the objective function as a quadratic function. The selected approach is analogous to the MPC approach that is widely used in practice. During the eighties of the last century, MPC became popular in process industries such as chemical plants and oil refineries. The formulation **Prob^C** can be interpreted as an elementary MPC problem that can be efficiently solved by quadratic programming solvers [Boyd and Vandenberghe, 2004]. All other formulations do result in constrained non-convex optimization problems due to presence of the detection aim.

The numerical solution presented in [Blackmore and Williams, 2006] is similar to the solution used in the thesis, however, it is less demanding due to absence of the control objective. The optimization problem that is solved in [Blackmore and Williams, 2006] can be interpreted as minimization of a concave quadratic func-

tion with convex constraints. The suboptimal solution proposed in this chapter can be used for computation of all problems presented in [Šimandl and Punčochář, 2009]. Only the state filtration will be more demanding because the assumptions in [Šimandl and Punčochář, 2009] are not so strict as the assumptions in this chapter.

Chapter 7

Numerical example

Two experiments that demonstrate the constrained optimization approach to AFDC are presented in this chapter. The first experiment is intended to graphically illustrate the shapes of the objective functions and the instantaneous as well as sum constraint sets. The second experiment demonstrates the design of the input sequence \mathbf{u}_0^{F-1} using a simple fault detection and control problem. For the sake of a clear demonstration, simple scalar models are used. The parameters of two models that are used in both experiments are as follows

$$\begin{aligned} \mathbf{A}_1 &= 0.8, \quad \mathbf{A}_2 = 0.1, \quad \mathbf{B}_1 = 0.1, \quad \mathbf{B}_2 = 0.45, \\ \mathbf{C}_1 &= \mathbf{C}_2 = 1, \quad \mathbf{G}_1 = \mathbf{G}_2 = \mathbf{H}_1 = \mathbf{H}_2 = 0.4. \end{aligned} \quad (7.1)$$

The initial condition \mathbf{x}_0 is given by its mean $\hat{\mathbf{x}}_0 = 0$ and covariance $\Sigma_{x_0} = 0.1$. The matrices in the control cost function are chosen as $\mathbf{Q}_k = 0$, $\mathbf{R}_k = 1$, and the initial probabilities of models are set to $P(\mu = 1) = P(\mu = 2) = 0.5$.

7.1 Objective function and constraint sets demonstration

In the first experiment all five principal formulations are considered. Besides illustrating the shapes of the objective functions and the constraint sets, the influence of the sum constraints is highlighted. Prediction horizon is chosen $F = 2$. The short prediction horizon allows for visualization of objective function and constraints. The instantaneous input constraints are $\mathcal{U}_k = \{u_k \in \mathbb{R} : -5 \leq u_k \leq 5\}$ for all $k \in \mathcal{T}$ and there are no instantaneous expectation state constraints. The limit values for the sum constraints are $J_{\max}^D = 0.3$ and $J_{\max}^C = 25$, and the weighting factor $\alpha = 0.9999$ is used in **Prob^{CD}**.

The experiment results are summarized in the following list.

Prob^C

Since the control objective function $J^C(\mathbf{u}_0^{F-1*})$ is strictly convex and the mean value of the initial state $\hat{\mathbf{x}}_0$ is zero, the minimum of the control objective function is attained at $\mathbf{u}_0^{1*} = [0, 0]^T$. This input sequence also fulfills all instantaneous constraints and therefore it is the optimal solution of **Prob^C**, see

Fig. 7.1(a).

Prob_D^C

The detection sum constraint determines a non-convex set that excludes input sequences close to the origin and prevents insufficient excitation of the monitored system (for example, the solution of **Prob^C** $\mathbf{u}_0^{1*} = [0, 0]^T$ violates the detection sum constraint). The solution of **Prob_D^C** lies on the boundary of the detection sum constraint set, see Fig. 7.1(a).

Prob^{CD}

The objective function of **Prob^{CD}** is a weighted sum of a convex function and a log-concave function, therefore, no general statement about the solution can be made. In contrast to other principal formulations, there are **Prob^{CD}** set-ups when none of the constraints is active. In the current example, the solution **Prob^{CD}** lies on the boundary of the instantaneous input constraints, see Fig. 7.1(b).

Prob_C^D

The detection objective functions $J_B^D(\mathbf{u}_0^{F-1})$ is concave and the instantaneous input as well as the control sum constraint constraints set are convex. Therefore, the minimum lies on the boundary of the intersection of constraint sets. The control sum constraint defines a disk $\{\mathbf{u}_0^1 \in \mathbb{R}^2 : (u_0)^2 + (u_1)^2 \leq 25\}$ with the center at the origin. Since the disk is entirely inside the set \mathcal{U} , the solution of **Prob_C^D** lies on the boundary of the control sum constraints, see Fig. 7.1(c).

Prob^D

In contrast to **Prob_C^D**, no sum constraints are considered, therefore, the solution of **Prob^D** lies on the boundary of instantaneous constraint set, see Fig. 7.1(c).

7.2 Simple active fault detection and control problem

The goal of the second experiment is to demonstrate all principal formulations using a simple AFDC problem. The second experiment also focuses on a comparison of passive and active approaches to fault detection. The instantaneous input constraints are $\mathcal{U}_k = \{u_k \in \mathbb{R} : 0 \leq u_k \leq 5\}$ for all $k \in \mathcal{T}$. The the instantaneous expectation state constraints are $\mathcal{X}_{k|\mu_k} = \{\hat{\mathbf{x}}_{k|\mu_k} \in \mathbb{R} : 0 \leq \hat{\mathbf{x}}_{k|\mu_k}\}$ for all $0 \leq k \leq 10$ and $\mathcal{X}_{k|\mu_k} = \{\hat{\mathbf{x}}_{k|\mu_k} \in \mathbb{R} : 1 \leq \hat{\mathbf{x}}_{k|\mu_k}\}$ for all $10 < k \leq F$, where $F = 14$ and $\mu_k \in \mathcal{M}$. The sum constraints limits are $J_{\max}^D = 0.2$, $J_{\max}^C = 140$, and the weighting factor is $\alpha = 0.998$.

The numerical results of the experiment are summarized in Tab. 7.1. There are also results of 10000 Monte Carlo simulations. The Monte Carlo simulations are used for experiment validation. It can be seen, that the Monte Carlo estimates of the detection objective function denoted as $J_{\text{MC}}^{\text{D}}(\mathbf{u}_0^{F-1*})$ are always smaller than the upper bound of the detection objective function $J_{\text{B}}^{\text{D}}(\mathbf{u}_0^{F-1*})$.

Differences between the input sequences and differences between the the expected state trajectories are illustrated in Fig. 7.2 and discussed in the following paragraphs. Note that the expected output trajectories are the same as the expected state trajectories ($C = 1$).

Prob^C

The input sequence is designed regardless of the detection aim. Therefore, the minimum control effort that ensures the fulfillment of instantaneous constraints is exerted. It can be seen from Fig. 7.2(a) that the expected state trajectories for both models are very similar and therefore the given detector cannot distinguish the models easily.

Prob^D

Since the goal is to minimize the detection objective function and there is no control objective, the optimal input sequence oscillates between the minimum and maximum values defined by the input instantaneous constraints in order to perform the best excitation of the system, see Fig. 7.2(b). Such an input sequence ensures good detector performance (less than one percent of misclassification according to Monte Carlo simulations). However, the control objective is almost four times higher than in **Prob^C**.

Prob_D^C, Prob_C^D, Prob^{CD}

The problem formulations **Prob_D^C**, **Prob_C^D**, and **Prob^{CD}** make it possible to overcome the mentioned drawbacks of **Prob^D** and **Prob^C** by finding the input sequence that represents an optimal trade-off between the competing aims of AFDC. The problem formulation **Prob_D^C** was chosen as a representative example of formulations **Prob_D^C**, **Prob_C^D**, and **Prob^{CD}**. Figure 7.2(c) shows that the detection sum constraint causes a small oscillation of the input signal that allows for better distinction between the expected state trajectories without any significant increase in the control objective function. It can be seen in Tab. 7.1 that all the sum constraints are fulfilled. In case of **Prob_D^C**, the detection objective had to be smaller than or equal to 0.2 and it is 0.2. In case of **Prob_C^D**, the control objective had to be smaller than or equal to 140 and it is 139.96.

The Pareto frontier depicted in Fig. 7.3 provides a helpful insight into the trade-off between detection and control objectives. Each point of the Pareto frontier represents a solution of a multi-objective optimization problem where the solution

cannot be improved in one objective without worsening in the other objective. When \mathbf{Prob}^C and \mathbf{Prob}_D^C are compared, it can be seen that a small increase of the control cost can result into a significant improvement of the detection cost. On the other hand, comparison of \mathbf{Prob}_C^D and \mathbf{Prob}^D shows that in some cases even a substantial increase of the control cost does provide only an insignificant improvement of the detection cost.

The problem formulation \mathbf{Prob}^C can be seen as an example of the passive fault detection. Some control action is needed in order to fulfil the time varying instantaneous expectation state constraints, however, the input sequence design is not influenced by any detection objective and therefore the control action may not provide a sufficient system excitation. All the other cases represent the active fault detection approach because the detection objective is considered during the input signal design. In accordance with the expectation, the highest value of the detection objective function was obtained in \mathbf{Prob}^C . It confirms the presumption that the control and detection aims are in contradiction and that the active approach to fault detection is superior to the passive approach.

Table 7.1: Results of the second experiment, where $J_B^D(\mathbf{u}_0^{F-1*})$ denotes the upper bound of $J^D(\mathbf{u}_0^{F-1*})$ and $J_{MC}^D(\mathbf{u}_0^{F-1*})$ denotes estimated value of $J^D(\mathbf{u}_0^{F-1*})$ based on 10000 Monte Carlo simulations. It can be seen that both sum constraints were fulfilled ($J_B^D(\mathbf{u}_0^{F-1*}) \leq 0.2$ in case of \mathbf{Prob}_D^C and $J^C(\mathbf{u}_0^{F-1*}) \leq 140$ in case of \mathbf{Prob}_C^D). The formulation \mathbf{Prob}^C can be interpreted as an example of passive fault detection. All other formulation represent active fault detection approach. In accordance with the expectation, the active approach outperformed the passive approach to fault detection in terms of misclassification probability.

	$J^C(\mathbf{u}_0^{F-1*})$	$J_B^D(\mathbf{u}_0^{F-1*})$	$J_{MC}^D(\mathbf{u}_0^{F-1*})$
\mathbf{Prob}^C	52.42	0.2853	0.1353
\mathbf{Prob}_D^C	63.39	0.2000	0.0846
\mathbf{Prob}_{CD}^D	95.56	0.0936	0.0311
\mathbf{Prob}_C^D	139.96	0.0503	0.0160
\mathbf{Prob}^D	202.78	0.0385	0.0091

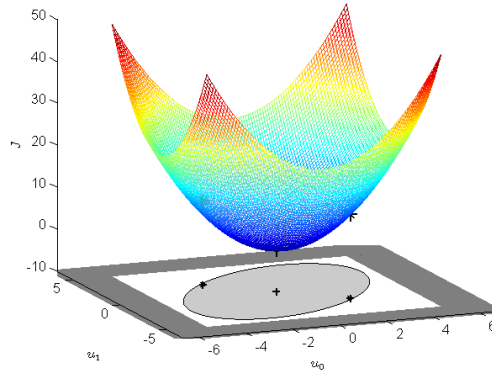

(a) solution of \mathbf{Prob}^C is denoted by the plus symbol, solutions to \mathbf{Prob}_D^C are denoted by the star symbols.

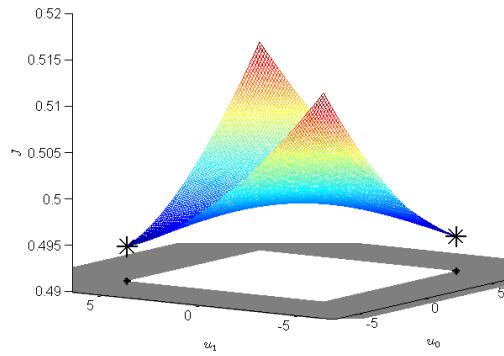

(b) Solutions to \mathbf{Prob}^{CD} are denoted by the star symbols.

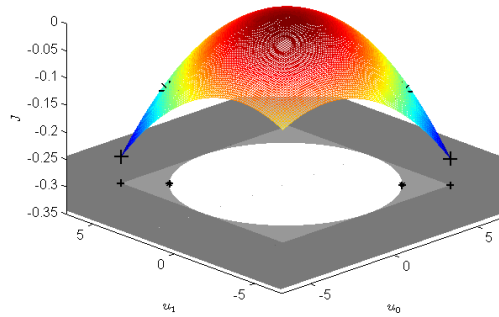

(c) Solutions to \mathbf{Prob}^D are denoted by the plus symbols, solutions to \mathbf{Prob}_C^D are denoted by the star symbols.

Figure 7.1: The dark gray area represents the set of inputs that do not satisfy the instantaneous input constraints. The light gray area represents the set of inputs that do not satisfy the sum constraints. The small plus and star symbols denote the optimal inputs \mathbf{u}_0^{1*} while the large symbols denote the corresponding optimal values $J(\mathbf{u}_0^{1*})$.

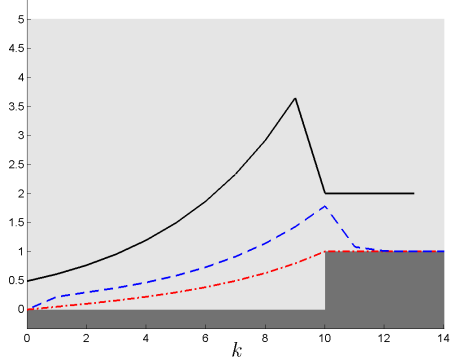

(a) The formulation $\mathbf{Prob}^{\mathbf{C}}$ is an example of passive fault detection.

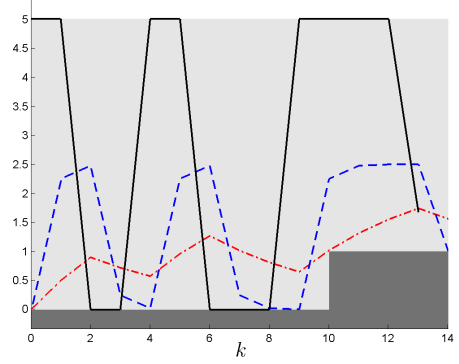

(b) The formulation $\mathbf{Prob}^{\mathbf{D}}$ is an example of active fault detection.

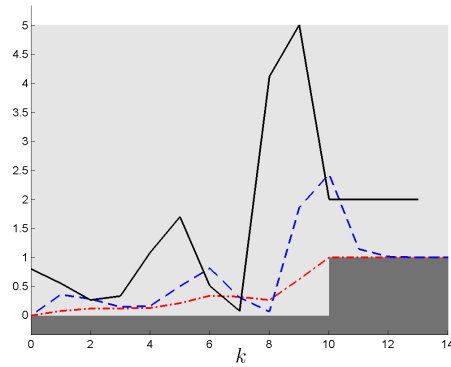

(c) The formulation $\mathbf{Prob}_S^{\mathbf{D}}$ is an example of active fault detection and control.

Figure 7.2: Results of the second experiment are depicted in a three figures. The light gray area represents the set of inputs that satisfy the instantaneous input constraints. The dark gray area represents the set of states that do not satisfy the instantaneous expectation state constraints. The input sequence \mathbf{u}_0^{F-1*} , the expected fault free state trajectory $\hat{\mathbf{x}}_{0|1}^F$ and the expected faulty state trajectory $\hat{\mathbf{x}}_{0|2}^F$ are represented by the black solid line, the red dash-dot line, and the blue dashed line, respectively.

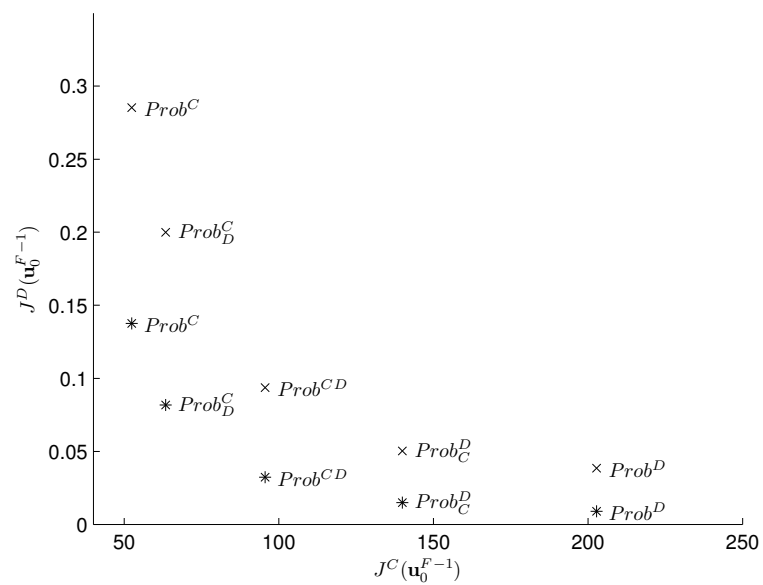

Figure 7.3: The crosses denote the upper detection objective bound $J_B^D(\mathbf{u}_0^{F-1*})$ while the stars denote the estimated value of the detection objective function based on 10000 Monte Carlo simulations $J_{MC}^D(\mathbf{u}_0^{F-1*})$.

Chapter 8

Air handling unit numerical example

The goal of this chapter is to demonstrate how AFDC can be used in practice. The application example focuses on an air handling unit (AHU). It covers the whole procedure of an active fault detector and controller design from a model construction, through constraints and the objective function definition, to a detailed discussion of results and implementation aspects.

Advanced control and fault detection of Heating, Ventilation, and Air Conditioning (HVAC) systems have gained a lot of attention during the last two decades [Wong et al., 2005, Han et al., 2010]. Processes in buildings are getting more difficult for operators to understand because contemporary buildings are complex systems and it is not an easy task to find a relation between cause and effect. There are thousands of measured values and it is not possible for an operator to evaluate all of them. Therefore, building optimal control and reliable fault detection is the major issue in building monitoring systems. Most of the faults result in inefficient usage of energy. The economic point of view is the main motivation for implementation of fault detection into buildings. Buildings account for 20–40 % of the total final energy consumption and its amount has been increasing at a rate 0.5–5 % *per annum* in developed countries [Perez-Lombard et al., 2008]. Another important aspect is the reduction of maintenance costs and more efficient usage of a maintenance staff. The increase of quality of living for occupants is also of great importance.

8.1 Overview of building control and fault detection methods

The short overview presented in this section firstly focuses on fault detection methods used in buildings with special attention to AHU fault detection. Afterwards, HVAC control techniques are discussed. Vast amount of HVAC control techniques have been studied and applied in practice. The overview of control techniques focuses on optimization based control techniques because these techniques are in accordance with the presented AFDC framework. Special attention is laid on AHU

control.

8.1.1 Building fault detection

Application of fault detection methods to buildings have been studied since the seventies of the last century. The major expansion started in the nineties of the last century [Katipamula and Brambley, 2005]. In the nineties, the International Energy Agency initiated a research project Annex 25. Results of Annex 25 are summarized in [Hyvärinen, 1996]. The fundamental topic of the book is the survey of fault detection and diagnosis methods for buildings. It involves several topics each requesting a different engineering knowledge. Lot of attention is laid on the comprehensive overview of typical HVAC faults. A wide range of fault detection related to buildings is presented in the book.

Many of fault detection methods are focused particularly on AHUs. Application of neural networks to AHU fault diagnosis was presented in [Lee et al., 1996]. A fault detection technique for an AHU that combines expert rules and performance indexes is described in [Qin and Wang, 2005]. Several classification techniques are considered for fault detection and diagnosis of a Variable Air Volume (VAV) AHU in [House et al., 1999]. A simple but robust technique using common sense rather than complicated mathematics was introduced in [House et al., 2001]. This technique is denoted as AHU performance assessment rules (APAR) and it consist of 28 if-then rules that are evaluated according to the operation regime of an AHU. The APAR received a lot of attention and this technique was further elaborated, e.g., in [Schein et al., 2006, Trojanova et al., 2009].

8.1.2 Optimization based building control

The aim of the following overview of building control methods is to show how the optimization based building control methods can exploit specific properties of buildings. The main challenges for optimal building control are active usage of a building's thermal mass, optimal operation of a thermal storage, power peak reduction and shifting, efficient usage of external heat sources and incorporation of a variable energy prices. It will be shown in this chapter that AFDC can also make use of these specifics and provide an energy efficient solution.

During the last two decades application of Model Predictive Control (MPC) to buildings was intensively studied. Application of MPC is meaningful especially in case of buildings that do have a slow thermal dynamics or an active thermal storage. A study presented in [Grünenfelder, 1985] was among the first papers which formulated the control of the thermal storage as an optimization problem. The control of a simple solar domestic hot water system considering the weather forecast and two energy rates is discussed there. Some early papers [Snyder and Newell, 1990, Henze et al., 2004] deal with a least-cost cooling strategy using the building mass as a thermal storage. An overview of the active use of the thermal building mass is given in [Braun, 2003], where a variable energy price and the cost of the peak power are considered in the formulation of the optimization problem. The controller that

minimizes cooling costs with respect to the time-varying electrical energy price is presented also in [Ma et al., 2009]. The aim is to take advantage of night-time electricity rates and to lower the ambient temperature while precooling the chilled water tank. Experimental results of precooling are presented in [Ma et al., 2010], where a more detailed building load model was used. Predictive control of heating using the thermal mass is discussed in e.g. [Cho, 2003, Chen, 2002]. A successful application of MPC to a university building in Prague is described in [Široký et al., 2011a, Prívarva et al., 2011, Ferkl and Široký, 2010]. Energy savings making use of MPC in relation to different thermal comfort criteria is discussed in [Freire et al., 2008]. Besides the energy minimization, predictive control can also contribute to power peak reductions [Rijksen et al., 2010, Katipamula et al., 2010]. Power peak reduction can significantly lower the costs of the building operation and initial cost of mechanical parts if considered in the building design. Electrical grid load and power peak reduction was considered in [Oldewurtel et al., 2010]. Predictive control used for the sizing of heating systems for discontinuously occupied buildings is discussed in [Hazyuk and Ghiaus, 2010], where the model is decoupled into four simple RC models which allowed modeling of the contribution of outdoor air temperature, solar radiation, and internal gains separately. There were numerous attempts to utilize other optimization based control techniques that are well-known in industrial process control also for building control [Dounis and Caraiscos, 2009]. The general dynamic programming problem for the control of a borehole thermal energy storage system is solved in [Vanhoudt et al., 2010], where the aim is to guarantee the delivery of heat or cold all year around while minimizing the operational costs. A reinforcement learning technique used for a building thermal storage control is outlined in [Liu and Henze, 2006a, Liu and Henze, 2006b]. The real building experiment provided only 8.3% cost savings because the thermal storage has been only partially utilized by the learning control strategy. Genetic algorithms and simulated annealing were used for optimal control of cooling in [Spindler and Norford, 2009]. The objective was to design an economically optimal use of a natural ventilation, fan-driven ventilation, and a mechanical air conditioning with respect to indoor temperature requirements. A comprehensive and continuously updated overview of the literature related to advanced building control can be found on the web site of the OptiControl project¹.

In the recent years, optimization based techniques have been applied also to control of AHUs. A model based approach to optimal VAV air-conditioning system is presented in [Xu et al., 2009]. A genetic algorithm is used for solving a nonlinear optimization problem. The cost function expresses the trade-off among the five main objectives: thermal comfort, indoor air quality, maximum allowed relative humidity, total ventilation rate and energy usage. A similar approach to air conditioning system using a genetic algorithm is presented in [Mossolly et al., 2009]. Usage of the particle swarm optimization algorithm for reheat of the VAV boxes is presented in [Kusiak and Li, 2010]. Optimal control based on CO₂ concentration is discussed in [Kusiak and Li, 2009]. The control of CO₂ concentration is formulated as an multi-

¹www.opticontrol.ethz.ch

objective optimization that takes into account the following objectives: fan run time, average CO₂ concentration above the threshold and time when CO₂ concentration is above the threshold. Control of an AHU and set of VAV boxes is discussed in [Ma et al., 2011]. The authors use modifications of MPC, which allow to solve large scale problems.

8.2 Air handling unit model

An AHU is a device used to condition and circulate air as part of HVAC system. It is usually a large metal box containing a blower, heating and cooling elements, filter racks or chambers, sound attenuators, and dampers, see Figure 8.1. The AHU is usually connected to a ductwork ventilation system that distributes the conditioned air through the building and returns it to the AHU. The basic function of the AHU is to suck air from the rooms, mix it with the ambient air, let it pass through cooling and heating coils and then discharge the cooled or heated air back to the rooms, see Figure 8.2. Ratio between the fresh ambient air and air from rooms is maintained by means a air mixing damper.

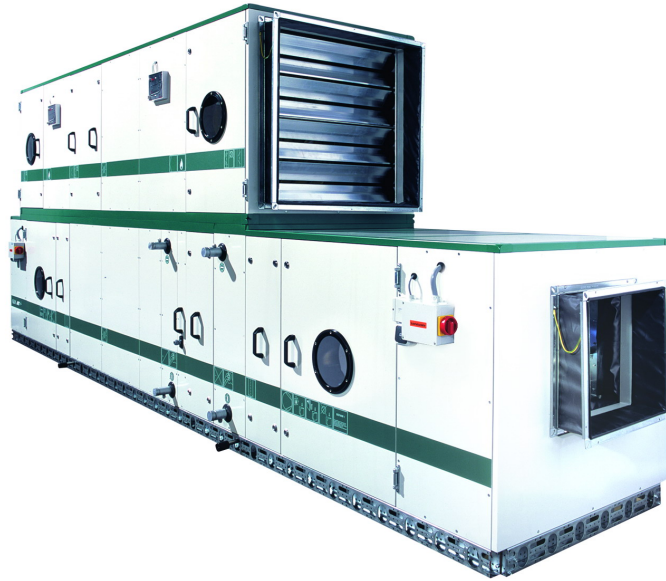

Figure 8.1: Air handling unit.

The AHU is susceptible to several faults. One of the common faults is stuck of the air mixing damper, usually caused by a mechanical failure. Besides economical losses, it can result into a significant thermal discomfort. For example, during a winter when the damper is stuck in the fully open position. Then the freezing ambient air sucked by the AHU poses a serious problem until the fault is detected. A stuck damper will be investigated in the application example. The fault detection objective is to determine if the damper is in the closed position as expected or if it

Table 8.1: AHU model symbols description

	unit	description	value
T_k^i	°C	Indoor air temperature	
T_k^a	°C	Ambient air temperature	
T_k^s	°C	Supply air temperature	
T_k^w	K	Unmeasurable noise	
T_k^h	K	Increase of T_k^s by the heating coil	[0, 15]
T_k^c	K	Decrease of T_k^s by the cooling coil	[-15, 0]
Δ		Damper position	[0, 0.9]
m	kg/s	Air mass supplied into the room	3.6
C_p	kJ/Kkg	Specific heat capacity of air	1.012
C	kJ/K	Thermal capacity of the room	3700
R	K/W	Thermal resistance of the outside wall	0.63
δ_t	s	Discrete time period	300

remained stuck in the fully opened position. Note, that a minimal amount of the fresh air has to be supplied into the room and the air mixing damper cannot be fully closed. The amount of minimum amount of the fresh air is determined by a regulation, however, usually at least 10% of the fresh air is required.

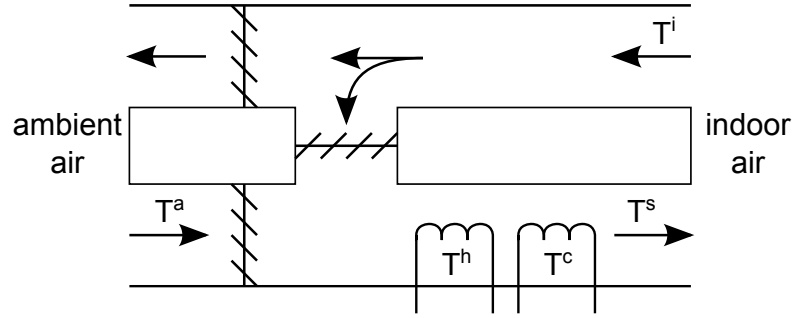

Figure 8.2: Air handling unit model.

The plant model is crucial for all model based control strategies. Detailed models of different AHU components are presented in [Ghiaus et al., 2007]. Each component is described by a physical model and model parameters are identified using grey-box identification methods. Similar level of detail of AHU components is discussed in [Lee et al., 1997]. Such level of detail is not needed for AFDC. A simplified AHU model that was used for example in [Ma et al., 2011] or [Wang, 1999] will be utilized in the thesis. The AHU model can be expressed as

$$T_{k+1}^i = T_k^i + \frac{mC_p}{C}(T_k^s - T_k^i)\delta_t + \frac{1}{RC}(T_k^a - T_k^i)\delta_t + T_k^w \quad (8.1)$$

$$T_k^s = \Delta T_k^i + (1 - \Delta)T_k^a + T_k^h + T_k^c.$$

The symbols are described in Table 8.1. The term $\frac{mC_p}{C}(T_k^s - T_k^i)$ expresses change of the room temperature caused by the air supplied by the AHU. The term

$\frac{1}{RC}(T_k^a - T_k^i)$ expresses change of the room temperature caused by heat losses. The unmeasurable noise T_k^w presents heat gains that could be caused by occupants or equipment and it also presents heat losses caused by manual ventilation. It is assumed, that T_k^w is Gaussian with zero mean and known variance. Heating and cooling coils are not controlled directly. It is expected that a low level controller (e.g. PID controller) is used for maintaining the required increase or decrease of the supply air temperature that is expressed by T_k^h and T_k^c . The mass flow rate is constant. Therefore, the energy use for heating and cooling is proportional to T_k^h and T_k^c .

The model (8.1) can be written as a state space model. The state is composed of the room air temperature and the ambient air temperature $\mathbf{x}_k = [T_k^i \ T_k^a]^T$, the input is composed of the heating and cooling coil set-points $\mathbf{u}_k = [T_k^h \ T_k^c]^T$ and the state noise is $w_k = T_k^w$. The state is not measured directly, only a noisy measurement of the room air temperature is available.

Based on a real position of the damper Δ , two models can be defined. The fault free model ($\Delta = 0.9$) and the faulty model with the stuck damper ($\Delta = 0$). Substituting two aforementioned values of the parameter Δ into (8.1), two state space models are

$$\mathbf{A}_1 = \begin{bmatrix} 1 - 0.1K_1 - K_2 & 0.1K_1 + K_2 \\ 0 & 1 \end{bmatrix}, \mathbf{A}_2 = \begin{bmatrix} 1 - K_1 - K_2 & K_1 + K_2 \\ 0 & 1 \end{bmatrix},$$

$$\mathbf{B}_1 = \mathbf{B}_2 = \begin{bmatrix} K_1 & K_1 \\ 0 & 0 \end{bmatrix}, \mathbf{C}_1 = \mathbf{C}_2 = \begin{bmatrix} 1 \\ 0 \end{bmatrix},$$

where $K_1 = \frac{mC_p}{C}\delta_t$, $K_2 = \frac{1}{RC}\delta_t$. The noise characteristics are given as follows

$$\mathbf{G}_1 = \mathbf{G}_2 = \begin{bmatrix} 0.3 & 0 \\ 0 & 0.3 \end{bmatrix}, \mathbf{H}_1 = \mathbf{H}_2 = \begin{bmatrix} 0.3 & 0 \\ 0 & 0.3 \end{bmatrix}. \quad (8.2)$$

The prediction horizon is 9 steps ($F = 8$), time period is 10 minutes.

8.3 Air handling unit experiments

The application example focuses on the optimal heating or cooling of a room in the morning after the night set-back. It is reasonable to carry out an AFD experiment before switching to the day regime when occupants move into the room. If a fault is detected, maintenance can be performed in order to prevent a major discomfort of the occupants.

Two different setups are presented in two sets of experiments. The first experiment set is denoted as cold morning experiments represents a situation when the room air is cold and some heat has to be delivered into the room in order to fulfill the comfort requirements. The second set of experiments denoted as warm morning experiments represents a situation when neither heat nor cold has to be delivered into the room. It will be shown that some control action can be enforced by the detection objective.

8.3.1 Experiments setup

The common parameters for all AHU experiments will be defined first. The input constraints are

$$\mathcal{U}_k = \left\{ \begin{bmatrix} T_k^h \\ T_k^c \end{bmatrix} : -15 \leq T_k^c \leq 0 \leq T_k^h \leq 15 \right\}, k \in \mathcal{T}. \quad (8.3)$$

The input constraints are given by a maximal heating and cooling gains of the heating and cooling coils, respectively. The state expectation constraints for the fault free model are referred to as comfort constraints and they are defined as follows

$$\mathcal{X}_{k|1} = \begin{cases} \{E\{T_k^i | \mu_k = 1\} : 18 \leq E\{T_k^i | \mu_k = 1\} \leq 25\} \dots k \leq 5, \\ \{E\{T_k^i | \mu_k = 1\} : 20 \leq E\{T_k^i | \mu_k = 1\} \leq 23\} \dots k > 5. \end{cases} \quad (8.4)$$

Narrowing of the constraints after the fifth time step represents the switch from the night set-back to the day regime.

The input signal has to be designed in the way that an acceptable level of comfort is maintained even if the damper is faulty. The state expectation constraints for the faulty model are referred to as emergency constraints and they are defined as follows

$$\mathcal{X}_{k|2} = \{E\{T_k^i | \mu_k = 2\} : 16 \leq E\{T_k^i | \mu_k = 2\} \leq 27\}, k \in \mathcal{T}. \quad (8.5)$$

The state variable expressing the ambient air temperature T_k^a is, of course, unconstrained in case of both models.

The control cost captures two different energy cost tariffs: the night tariff and the normal tariff

$$\mathbf{Q}_k = \begin{bmatrix} 0 & 0 \\ 0 & 0 \end{bmatrix}, \mathbf{R}_k = \begin{cases} \begin{bmatrix} 0.6 & 0 \\ 0 & 0.6 \end{bmatrix}, & k \leq t_{TS}, \\ \begin{bmatrix} 1 & 0 \\ 0 & 1 \end{bmatrix}, & k > t_{TS}, \end{cases}$$

where t_{TS} denotes time step when the night tariff switches to the normal tariff. The control objective function $J^C(\mathbf{u}_0^{F-1})$ can be seen as a monetary control cost. The tariff switching can be left out by setting $t_{TS} = -1$. The control objective function without the tariff switching will also be evaluated in order to demonstrate the effect of the tariff switching. If there is no tariff switching, the control cost can be interpreted as amount of used energy. Therefore it will be denoted as $J_e^C(\mathbf{u}_0^{F-1})$.

The model probabilities are $P(\mu_k = 1) = 0.9$ and $P(\mu_k = 2) = 0.1$. Each experiment set comprises eight experiments that are defined in Table 8.2. The tariff is switched at the third time step for all experiments with tariff switching (label with the symbol **T**). In case of experiments without the tariff switching $t_{TS} = -1$. The initial state pdfs are defined individually for each set of experiments.

Table 8.2: AHU experiments definition. The symbol **T** at the end of a label indicates that tariff switching is considered and ∞ indicates that a particular sum constraint is not used.

label	problem type	J_{\max}^C	J_{\max}^D	tariff switching
Prob^C	Prob^C	∞	∞	no
Prob^CT	Prob^C	∞	∞	yes
Prob_D^C	Prob_D^C	∞	0.1	no
Prob_D^CT	Prob_D^C	∞	0.1	yes
Prob_C^D	Prob_C^D	19	∞	no
Prob_C^DT	Prob_C^D	19	∞	yes
Prob^D	Prob^D	∞	∞	no
Prob^DT	Prob^D	∞	∞	yes

8.3.2 Cold morning experiments

The initial state pdf is defined by the first two moments

$$\hat{\mathbf{x}}_0 = \begin{bmatrix} 19 \\ 16 \end{bmatrix}, \Sigma_{x_0} = \begin{bmatrix} 1 & 0 \\ 0 & 1 \end{bmatrix}.$$

In other words, it is expected that the room temperature is 19°C and the ambient air temperature is 16°C. The required indoor air temperature (expressed by the fault free state expectation constraints) is higher than the expected initial room air temperature. It is also higher than the expected ambient air temperature. Therefore, some amount of heat has to be supplied into the room in order to fulfill the design requirements. The experiment results are summarized in Table 8.3, each special case will be discussed now.

Prob^C, Prob^CT

Solution to **Prob^C** provides important information about the minimal amount of energy that has to be delivered in order to fulfill the comfort requirements, see Figure 8.3. When the tariff switching is considered, heating is realized mainly in the last time step of the night tariff. The amount of energy $J_e^C(\mathbf{u}_0^{F-1})$ is higher in case of **Prob^CT**, however, the control objective function $J^C(\mathbf{u}_0^{F-1})$ is lower in case of **Prob^CT** due to utilization of the cheap night tariff.

Prob_D^C, Prob_D^CT

The pair of experiments **Prob_D^C** and **Prob_D^CT** is shown in Figure 8.4. The detection aim is expressed in form of the sum constraint $J_B^D(\mathbf{u}_0^{F-1}) \leq 0.1$ that is fulfilled in case **Prob_D^C** as well as in case **Prob_D^CT**. The tariff switching allows for a reduction of the control cost by 37.5%. The estimated probability of misclassification based on Monte Carlo simulations $J_{MC}^D(\mathbf{u}_0^{F-1})$ is smaller than the detection sum constraint $J_B^D(\mathbf{u}_0^{F-1})$ in both experiments.

Table 8.3: Results of the cold morning experiments, where $J^C(\mathbf{u}_0^{F-1})$ is the control cost when the tariff switching is applied, $J_e^C(\mathbf{u}_0^{F-1})$ is the control cost without tariff switching (only normal tariff is applied), $J_B^D(\mathbf{u}_0^{F-1})$ is the upper bound of the detection cost and $J_{MC}^D(\mathbf{u}_0^{F-1})$ is the detection cost estimate based on 10000 Monte Carlo simulations. All optimization problems were computed using the global optimization routine `bmibnb` and Intel Core i5 CPU, note that **Prob^C** and **Prob^CT** can be solved much faster by a specialized quadratic solver.

	$J^C(\mathbf{u}_0^{F-1})$	$J_e^C(\mathbf{u}_0^{F-1})$	$J_B^D(\mathbf{u}_0^{F-1})$	$J_{MC}^D(\mathbf{u}_0^{F-1})$	solution time [sec]
Prob^C	16.10	16.10	0.220	0.064	10.8
Prob^CT	12.75	19.02	0.180	0.040	9.7
Prob^C_D	25.19	25.19	0.100	0.013	82.9
Prob^C_DT	15.74	26.24	0.100	0.013	66.3
Prob^D_C	19.00	19.00	0.171	0.037	41.3
Prob^D_CT	19.00	31.67	0.052	0.003	17.6
Prob^D	43.89	43.89	0.043	0.002	124.7
Prob^DT	29.66	43.89	0.043	0.002	160.7

Prob^D_C, Prob^D_CT

Significant influence of the tariff switching can be seen also when **Prob^D_C** and **Prob^D_CT** are compared, see Figure 8.5. In both experiments, the control sum constraint $J_{\max}^C \leq 19$ is fulfilled but there is a remarkable difference in misclassification probability. The night tariff allows for excitation at the beginning of the experiment. The value of the detection objective function $J_B^D(\mathbf{u}_0^{F-1})$ in case **Prob^D_CT** is three times smaller than $J_B^D(\mathbf{u}_0^{F-1})$ in case of **Prob^D_C**. Note that the difference between $J_{MC}^D(\mathbf{u}_0^{F-1})$ of **Prob^D_C** and **Prob^D_CT** is even bigger.

Prob^D, Prob^DT

The experiments **Prob^D** and **Prob^DT** are depicted in Figure 8.6. The control cost is not considered at all. Therefore the night tariff makes no difference and solutions to **Prob^D** and **Prob^DT** are the same. The room temperature is pushed to the limits defined by the instantaneous state expectation constraints in order to maximize difference between the fault free and the faulty state trajectory. The room air is firstly heated up to the maximal acceptable air temperature, then cooling is used in order to fulfill narrowed comfort constraints and finally heating is used again to fulfill emergency as well as comfort constraints.

The cold morning experiments confirmed that the active approach to fault detection provides more reliable fault detection results than the passive approach. The passive approach is represented by **Prob^C** and **Prob^CT** while all other formulations can be seen as examples of the active approach to fault detection. It was shown

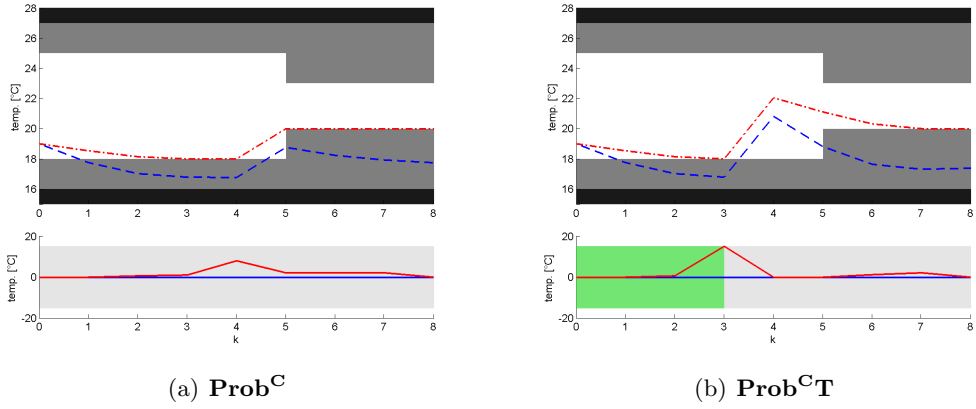

Figure 8.3: The expected states (the top charts) and inputs (the bottom charts) trajectories. In the top charts, the gray areas indicates the regions in which the comfort constraints are not satisfied. The dark gray areas indicate the regions in which the emergency constraints are not satisfied. In the bottom charts, the light gray areas indicate input values that do satisfy the input instantaneous constraints. The light green area indicates the time steps in which the night tariff is valid. In the top charts, the expected states $\hat{\mathbf{x}}_{0|1}^F$ and $\hat{\mathbf{x}}_{0|2}^F$ are represented by the red dash-dot line, and the blue dashed line, respectively. In the bottom charts, the solid red line indicates T_k^h and the solid blue line indicates T_k^c . Note that only the first elements T_k^i of the state vectors \mathbf{x}_k are depicted. The same description applies to Figures 8.6 - 8.9.

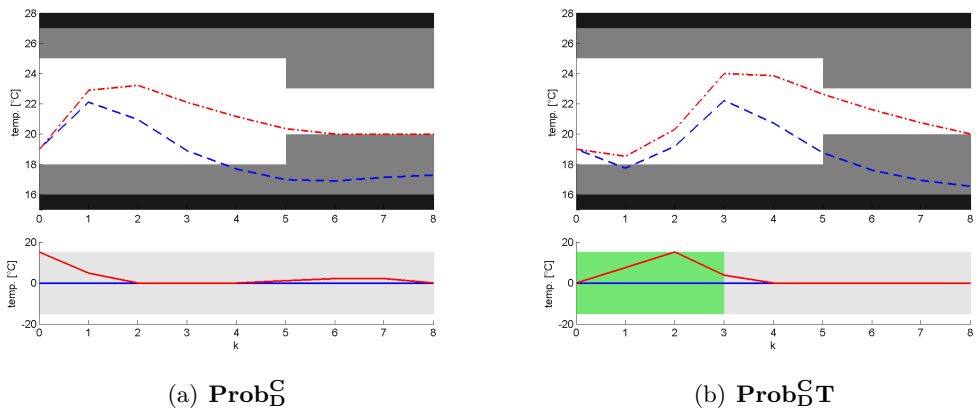
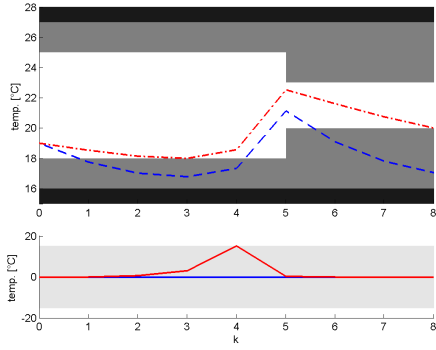
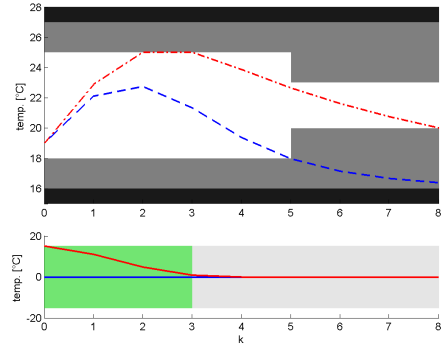

Figure 8.4: For the charts description see Figure 8.3



(a) Prob_C^D



(b) Prob_C^DT

Figure 8.5: For the charts description see Figure 8.3

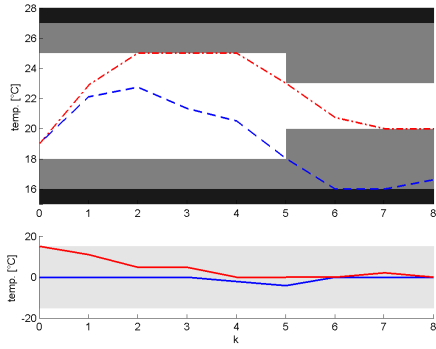

(a) Prob^D

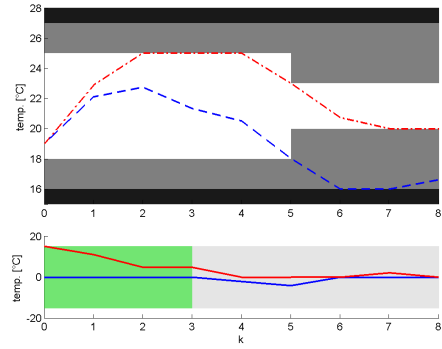

(b) Prob^DT

Figure 8.6: For the charts description see Figure 8.3

that the proposed AFDC framework can make use the time varying energy price. For example, in case of \mathbf{Prob}_C^D and \mathbf{Prob}_C^DT the utilization of the variable energy price allowed for reduction of misclassification probability from 0,171 to 0.052.

8.3.3 Warm morning experiments

The initial state pdf is defined as follows

$$\hat{\mathbf{x}}_0 = \begin{bmatrix} 21.5 \\ 21.5 \end{bmatrix}, \Sigma_{x_0} = \begin{bmatrix} 1 & 0 \\ 0 & 1 \end{bmatrix}.$$

The expected ambient air temperature is the same as the expected room air temperature and this temperature is exactly in the middle of the range given by the comfort and emergency constraints. Therefore, no action is needed to fulfill the state instantaneous state constraints. The experiment results are summarized in Table 8.4, each special case will be discussed now.

$\mathbf{Prob}^C, \mathbf{Prob}^{CT}$

No control action is needed in order to fulfill all instantaneous constraints. See Figure 8.7, where solution to \mathbf{Prob}^C and \mathbf{Prob}^{CT} is depicted. As expected, all inputs are zero regardless of the tariff switching.

$\mathbf{Prob}_D^C, \mathbf{Prob}_D^{CT}$

The problems \mathbf{Prob}_D^C and \mathbf{Prob}_D^{CT} are infeasible because the goal is to keep detection objective below 0.1 that is not possible without violation of the instantaneous constraints. The minimal value of the detection objective function $J_B^D(\mathbf{u}_0^{F-1})$ which is achieved by \mathbf{Prob}^D is 0.147, see Table 8.4.

$\mathbf{Prob}_C^D, \mathbf{Prob}_C^{DT}$

The detection aim enforces some control action that minimizes the detection objective function, see Figure 8.8. In both experiments heating as well as cooling is used in order to excite the AHU. Utilization of the night tariff allows reduction of $J_B^D(\mathbf{u}_0^{F-1})$ by 33%.

$\mathbf{Prob}^D, \mathbf{Prob}^{DT}$

The experiments \mathbf{Prob}^D and \mathbf{Prob}^{DT} are depicted in Figure 8.9. Similarly to the cold morning experiment, there is no difference between solution to \mathbf{Prob}^D and \mathbf{Prob}^{DT} . The expected fault free state is pushed to the limits defined by comfort constraints in order to minimize $J_B^D(\mathbf{u}_0^{F-1})$.

The cold morning experiment illustrates the key difference between the active approach and the passive approach to fault detection. Thanks to the experiments setup, no action is needed in order to fulfill the comfort requirements. Therefore the probability of misclassification is high in case of \mathbf{Prob}^C and \mathbf{Prob}^{CT} . In case of active approach, the detection objective function causes AHU excitation that significantly reduces the probability of misclassification. The experiments \mathbf{Prob}_D^C and \mathbf{Prob}_D^{CT} demonstrate that the sum constraints have to be chosen reasonably,

Table 8.4: Results of the warm morning experiments, where $J^C(\mathbf{u}_0^{F-1})$ is the control cost when the tariff switching is applied, $J_e^C(\mathbf{u}_0^{F-1})$ is the control cost without tariff switching (only normal tariff is applied), $J_B^D(\mathbf{u}_0^{F-1})$ is the upper bound of the detection cost and $J_{MC}^D(\mathbf{u}_0^{F-1})$ is the detection cost estimate based on 10000 Monte Carlo simulations. All optimization problems were computed using the global optimization routine **bmibnb** and Intel Core i5 CPU, note that **Prob^C** and **Prob^CT** can be solved much faster by a specialized quadratic solver. Problems **Prob^C_D** and **Prob^C_DT** are unfeasible due to the detection sum constraints that cannot be fulfilled.

	$J^C(\mathbf{u}_0^{F-1})$	$J_e^C(\mathbf{u}_0^{F-1})$	$J_B^D(\mathbf{u}_0^{F-1})$	$J_{MC}^D(\mathbf{u}_0^{F-1})$	solution time [sec]
Prob^C	0.00	0.00	0.294	0.106	12.7
Prob^CT	0.00	0.00	0.294	0.098	14.9
Prob^C_D	n/a	n/a	n/a	n/a	176.0
Prob^C_DT	n/a	n/a	n/a	n/a	142.2
Prob^D_C	19.00	19.00	0.210	0.061	164.8
Prob^D_CT	19.00	30.70	0.162	0.033	172.1
Prob^D	35.38	35.38	0.147	0.024	129.9
Prob^DT	28.31	35.38	0.147	0.025	157.6

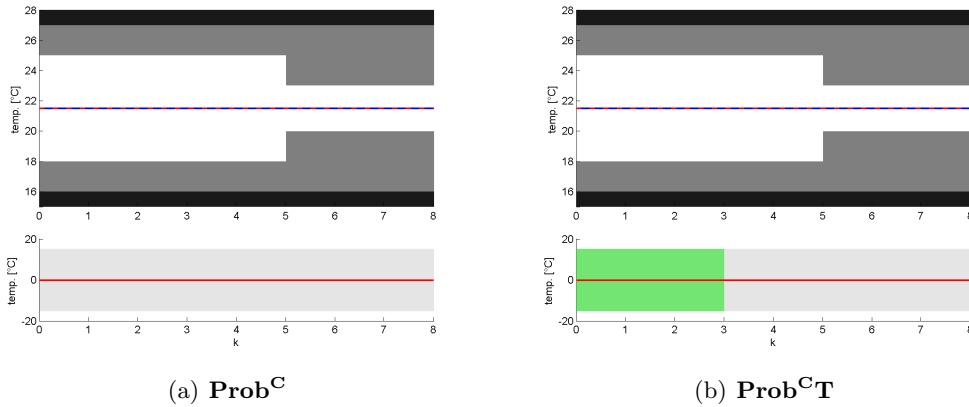
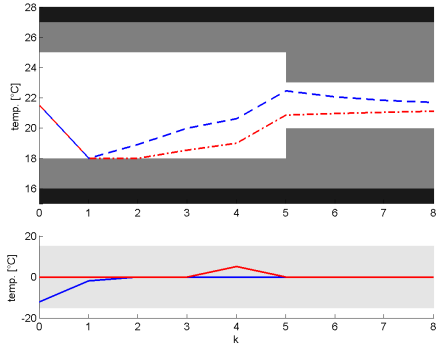
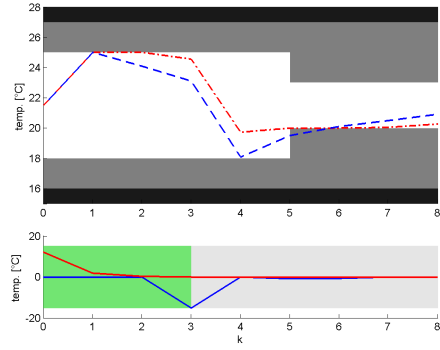

Figure 8.7: For the charts description see Figure 8.3



(a) Prob_C^D



(b) Prob_C^DT

Figure 8.8: For the charts description see Figure 8.3

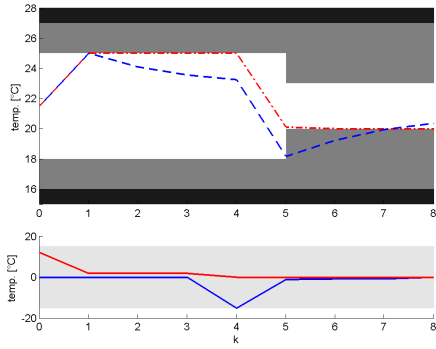

(a) Prob^D

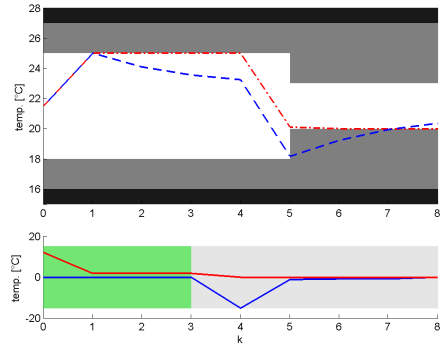

(b) Prob^DT

Figure 8.9: For the charts description see Figure 8.3

Table 8.5: Analysis of state expectation constraints violation for **Prob^C** and **Prob^D**, cold morning experiments set. The symbol $\bar{T}_k^i|_{\mu=1}$ denotes the arithmetic mean of T_k^i when μ_1 . The symbol $\bar{T}_k^i|_{\mu=2}$ denotes the arithmetic mean of T_k^i when μ_2 . Arithmetical means in the table are based on the same 500 Monte Carlo simulations as depicted in Figures 8.10.

k	Prob^C		Prob^D	
	$\bar{T}_k^i _{\mu=1}$	$\bar{T}_k^i _{\mu=2}$	$\bar{T}_k^i _{\mu=1}$	$\bar{T}_k^i _{\mu=2}$
0	18.92	18.90	18.96	18.87
1	18.47	17.65	22.86	21.92
2	18.10	16.93	25.00	22.52
3	17.97	16.75	25.03	21.17
4	17.96	16.74	25.04	20.24
5	19.97	18.69	23.05	17.77
6	19.98	18.12	20.79	15.77
7	20.00	17.87	20.05	15.75
8	20.01	17.78	20.09	16.41

otherwise the AFDC problem can become unfeasible. This issue can be solved by introduction of so-called slack variables [Maciejowski and Jones, 2003] that allow for violation of sum constraints. The sum constraints violation is then penalized in the objective function.

8.3.4 Monte Carlo verification

Two experiments (**Prob^C** and **Prob^D**) from the cold morning experiments set will be analyzed. The result of 500 Monte Carlo simulations is depicted in Figure 8.10. It can be seen that the fault free and faulty state trajectories are overlapping in case of **Prob^C**. The fault free and faulty state trajectories cannot be easily distinguished. This fact is confirmed also by Monte Carlo simulations. There were 27 misclassifications from the total 500 simulations. In case of **Prob^D**, the fault free and faulty state trajectories can be easily distinguished. None of the 500 ended up with a misclassification. These results are in accordance with the results based on 10000 Monte Carlo simulations summarized in Table 8.3.

Fulfillment of instantaneous state expectation constraints can be analyzed on the basis of the Monte Carlo simulations. The simulation results are summarized in Table 8.5. The expected fault free state is pushed to the margin given by comfort constraints in case of **Prob^C** in time steps $k = 3, 4, 5, 6, 7, 8$, see also Figure 8.3. The arithmetical mean $\bar{T}_k^i|_{\mu=1}$ is close to the lower comfort constraint (i.e. 18°C and 20°C). In the time steps 3 – 6, the arithmetical mean $\bar{T}_k^i|_{\mu=1}$ is below the lower comfort constraint. Note that it does not mean that the state expectation constraints are not fulfilled. The expectation constraints do not provide any guarantee for a set of realizations. The expectation constraints do guarantee that the expected value will fulfill the design requirements expressed by the constraints.

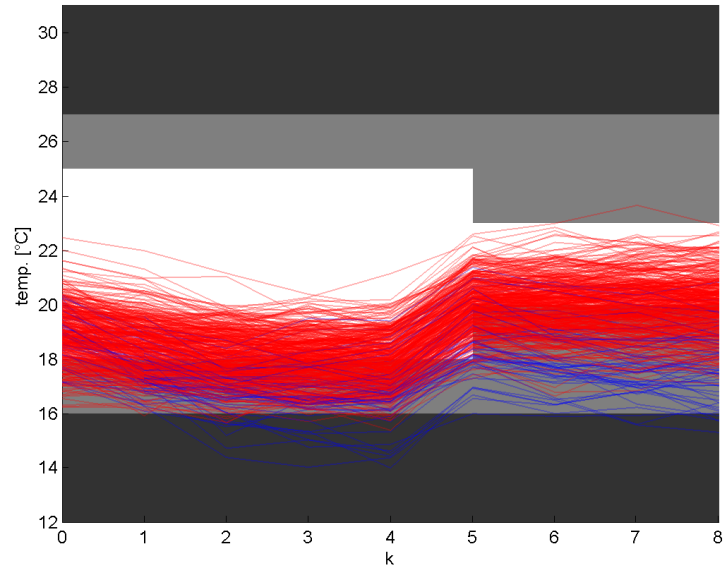

(a) In case of \mathbf{Prob}^C , the the fault free and faulty state trajectories are overlapping and they cannot be easily distinguished (27 of 500 Monte Carlo simulations ended up with misclassification).

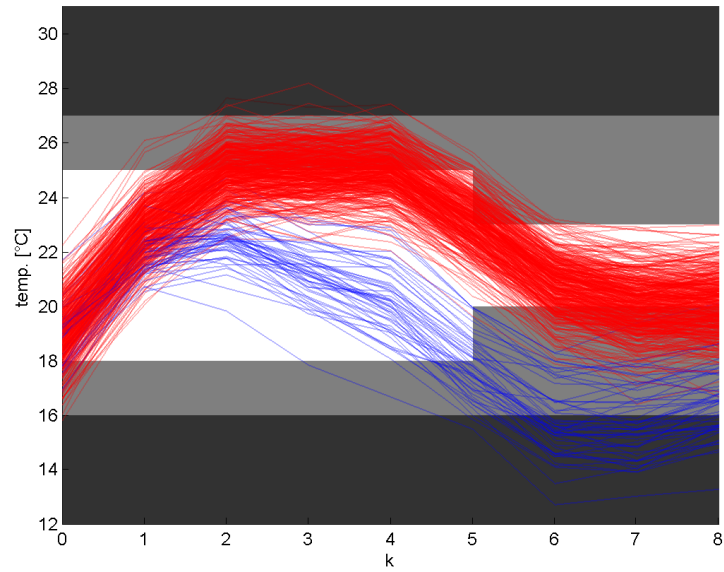

(b) In case of \mathbf{Prob}^D , the fault free and faulty state trajectories can be readily distinguished (none of 500 Monte Carlo simulations ended up with misclassification).

Figure 8.10: State trajectories of 500 Monte Carlo simulations, the cold morning experiments set. The fault free state trajectories are red. The faulty state trajectories are blue. Note that only the first elements T_k^i of the state vectors \mathbf{x}_k are depicted. Gray areas indicate the constraints sets, their descriptions is the same as in Figure 8.3.

Implementation aspects

All AFDC experiments presented in the thesis were coded in MATLAB using toolbox YALMIP. The main motivation for using YALMIP is rapid algorithm development. A modeling language introduced by YALMIP allows for natural notation of optimization problems regardless of the solver that is finally used. This feature is illustrated by the following code snippet that captures the main loop where the AHU AFDC problem is formulated and the sum constraints and objective function are defined.

```
for i=1:F
    %input vector
    u = [Th{i}; Tc{i}];

    % fault free model
    y1{i} = C * x1{i};
    x1{i+1} = A1 * x1{i} + B * u;

    % faulty model
    y2{i} = C * x2{i};
    x2{i+1} = A2 * x2{i} + B * u;

    % constraints
    constraints = [constraints, ...
        0 <= Th{i} <= HeatingMaxGain, ... % heating constraints
        CoolingMaxGain <= Tc{i} <= 0, ... % cooling constraints
        Treq_low(i) <= y1{i} <= Treq_hig(i), ... % comfort constraints
        Treq_low_fault <= y2{i} <= Treq_hig_fault, ... % emergency constraints
        Th{i} == 0 | Tc{i} == 0]; % AHU cannot heat and cool at the same time

    % constrol cost
    controlCost = controlCost + HeatingCost(i) * Th{i} + CoolingCost(i) * Tc{i};
    controlCostWithoutNightTariff = controlCostWithoutNightTariff + Th{i} - Tc{i};
end;

% sum constraints definition
if (constrainedByDetection)
    constraints = [constraints, ...
        EvaluateBhattacharyya(y1a', y2a', sig1, sig2, P1prob, P2prob) ...
        <= maxMisclasificationProb];
end
if (constrainedByControl)
    constraints = [constraints, controlCost <= maxControlCost];
end
if (detectionAsObjective)
    objective = -(y1a - y2a)*inv(sig1 + sig2)*(y1a - y2a)';
end;
if (controlAsObjective)
    objective = controlCost;
end;
```

It can be seen that the notation is readable and one can easily keep consistency between the code and the equations. The advantage of using YALMIP became even more evident when the optimization problem has to be solved. The following code sets solver parameters and then solves the optimization problem.

```
options = sdpsettings('solver','bmibnb', 'bmibnb.lowersolver', ...
'cplex','bmibnb.ubbersolver','snopt', 'bmibnb.maxiter', 50);
solutionInfo = solvesdp(constriants, objective, options)
```

The command `solvesdp` translates the optimization problem into a formulation that is required by a particular solver. This level of abstraction allows an easy switching between different solvers. One can focus on the formulation of the optimization problem and does not have to pay attention to conventions used by a particular solver.

The solution strategy is based on non-convex global optimization, therefore the computational performance cannot in general be expected to be tractable. Hence, the proposed solution is not suitable for real-time applications. Nevertheless, some simplified real-time AFDC system can be derived off-line based on AFDC solution analysis. For example, the proposed AFDC can be used for experiment design when several input trajectories are pre-computed and one of them is selected according to a current state during the on-line operation.

8.4 Discussion

The application of constrained AFDC to the AHU example approved the applicability of the proposed approach. Monte Carlo simulations confirmed that all sum constraints as well as state expectation constraints were met. It was shown, that the AFDC framework allows for exploiting building dynamics and provide energy efficient solutions. Similarly to MPC, AFDC can shift the power peak demand when a variable energy price is applied. This aspect is beneficial especially for active fault detection. The excitation of an AHU is done when energy price is low. In case of **Prob_D^C** the variable energy price allowed design of a cheaper AHU excitation. Cost of the excitation was reduced by 40% when the variable energy price was taken into account. In case of **Prob_C^D** utilization of the variable energy price significantly improved detection capabilities. According to Monte Carlo simulations, the rate of misclassification was reduced ten times thanks to exploitation of the variable energy price.

Chapter 9

Conclusion

The thesis focuses upon formulating a general framework for AFDC, derivating and demonstrating a solution to the problems defined within the AFDC framework. The AFDC framework allows to precisely formulate AFDC problems and to deal with the contradicting aims of AFDC. Detection and control aims can be expressed as objective function or as a constraint. The AFDC problems are formulated as constrained optimization problems within the presented AFDC framework. It was shown, that there is no general technique of deriving a numerically tractable optimal solution. The optimal solution can be found for a small subset of AFDC problems only. Nevertheless, when carefully designed, a suboptimal solution can be used instead of the optimal one. A procedure for suboptimal solution design was demonstrated using linear Gaussian models and common control and detection objectives. The numerical solution is based on global optimization solvers. The solution was computed using a branch and bound solver that allowed to analyze different scenarios and to demonstrate the key properties of AFDC problems. Finally, the applicability of the AFDC framework was illustrated on the example that was focused on optimal control and diagnosis of AHU. Each of three sub-goals of the thesis will be discussed in detail and the main achievements will be highlighted.

1 - Formulation of general active fault detection and control framework

The first goal of the thesis was to formulate an AFDC framework. The AFDC framework formulation was inspired by the unified AFDC formulation defined in [Šimandl and Punčochář, 2009]. Two major extensions of the unified AFDC formulation were introduced. The first extension was about incorporating a given detector into the AFDC framework. This enables the treatment of various practical setups. An example would be a safety critical process when redundant hardware detectors are already installed and the goal is to design a controller that fulfills control requirements and improves performance of the installed detectors. The second major extension was to introduce sum and state expectation constraints. The state expectation constraints allow expressing of physical and logical limitations of the controlled and monitored system. The state expectation constraints are expressed for each model separately. It allows, for example, to define different state expectation constraints

for the fault free model and for the faulty model. The sum constraints allow for expressing detection or control requirements as a constraint instead of an objective function. Thanks to the sum constraints, the excitation of a monitored system designed by the active fault detector can be constrained by a maximal control cost. Symmetrically, the controller can be constrained in a way that a predefined detection reliability has to be guaranteed. There can be a variety of practical AFDC formulations derived from the proposed AFDC framework. Five principal AFDC formulations covering different design requirements are discussed in the thesis. The main highlights of the first sub-goal can be summarized as follows.

- Detection and control aim can be expressed either as a part of the objective function or as a sum constraint.
- Design of a AFDC system can further be constrained by a given detector, a given controller, input constraints and state expectation constraints.
- Five principal formulations representing the most important AFDC formulation were defined. The principal formulations include an optimal controller and an active detector as marginal cases.

2 - Active fault detection and control problems solution

Introduction of state expectation and sum constraints substantially extended the capabilities of the AFDC framework on the other hand it also unexpectedly complicated the solution of the AFDC problems. The initial idea was to rely on dynamic programming and employ some of approximate dynamic programming techniques presented by Dimitri Bertsekas [Bertsekas, 2005a] for the solution of AFDC problems. However, the state expectation and sum constraints defined in the AFDC framework cause that the backward recursion, the key technique of dynamic programming, cannot be used. Surprisingly, it was not easy to find a literature dealing with dynamic programming in conjunction with the state expectation or state chance constraints.

The alternative goal was to derive a suboptimal solution at least for a representative subset of AFDC problems. In derivation of a suboptimal solution, the focus was narrowed to linear Gaussian models with quadratic control cost and detection objective based on maximization of a posterior probability. The key idea was to reformulate the stochastic optimization problem to a deterministic optimization problem where the solution of the deterministic problem guarantees the fulfillment of all stochastic requirements. It was easily done for control cost function and state expectation constraints. In case of detection objective function a lower bound had to be used. A suboptimal solution was derived for all five principal formulations. Four of five principal formulations required use of a global optimization solver. The main highlights of the second sub-goal can be summarized as follows.

- Only a subset of AFDC problems can optimally be solved by dynamic programming.

- A suboptimal solution was derived for Gaussian linear systems with a quadratic cost function and a given detector based on a posterior probability maximization.
- The suboptimal solution is numerically tractable for all five principal formulations.

3 - Illustrative examples and applicability demonstration

The key aspects of AFDC were demonstrated using a simple scalar model. Shapes of constraint set as well as objective functions were graphically illustrated. The trade-off between detection and control objectives was demonstrated by an outline of Pareto frontier. Monte Carlo simulations confirmed that all design requirements were met. All five principal formulations were investigated. A more complex example was also presented in order to prove applicability of the proposed AFDC framework in practice. The goal was to control and diagnose AHU using different setups and design requirements. It was shown that AFDC framework can make use of a time varying energy tariff and provide an economically effective solution for AHU AFDC. The main highlights of the third sub-goal can be summarized as follows.

- The key AFDC principles were illustrated by means of simple numerical examples.
- The AHU application example approved that the proposed AFDC framework has a potential for practical applicability.
- The proposed AFDC framework can make use of recent trends in energy systems such as variable energy price.

Active fault detection and control prospective application and further research

One of the recent trends in energy systems is the integration of buildings into so-called smart grids. Smart grids are beginning to be used on electricity networks, from the power plants and wind farms all the way to the consumers of electricity in homes and businesses. Smart grids are based on two-way communication, the energy price is time varying and each consumer and producer has to be able to react to changes of the grid. Variability of energy price is increasing due to renewable energy sources and more flexible energy markets are expected. Many research teams deal with design of building control concepts that allow the utilization of time varying energy prices. The experiments presented in the thesis show that time varying tariffs can be utilized also by active fault detection. It was shown that there are situations when a probing signal can be added without any significant increase of the total cost. One can imagine, that HVAC appliance can perform automatic AFDC self-diagnosis when low energy price is expected.

It was mentioned that the numerical solution relies on a global optimization solver and therefore it shall not be used in real-time applications. There are two ways how to deal with this issue. The first is to analyze the solution offline and derive some simplified version of AFDC. This can be done for example by means of machine learning. The second way is to focus on specific properties of AFDC optimization problems, exploit these properties and develop a solver tailored to AFDC problems.

Usage of instantaneous state constraints is essential for process control, but there are fields of application where instantaneous state constraints are not so important such as Econometrics. Numerical solution can be substantially simplified thanks to strong duality of the AFDC problems when instantaneous state constraints are not considered. It will be interesting to find out a practical application of AFDC framework with the presented suboptimal solution in Econometrics and provide a numerically efficient solution.

Bibliography

- [Andjelkovic et al., 2008] Andjelkovic, I., Sweetingham, K., and Campbell, S. (2008). Active fault detection in nonlinear systems using auxiliary signals. In *American Control Conference, 2008*, pages 2142–2147, Seattle, Washington. IEEE.
- [Bar-Shalom, 1981] Bar-Shalom, Y. (1981). Stochastic dynamic programming: Caution and probing. *IEEE Transactions on Automatic Control*, 26(5):1184–1194.
- [Bar-Shalom and Tse, 1974] Bar-Shalom, Y. and Tse, E. (1974). Dual effects, certainty equivalence and separation in stochastic control. *IEEE Transactions on Automatic Control*, 19(5):494–500.
- [Basseville and Nikiforov, 1993] Basseville, M. and Nikiforov, I. V. (1993). *Detection of Abrupt Changes – Theory and Application*. Prentice Hall, Englewood Cliffs, NJ, USA.
- [Bateman et al., 2008] Bateman, F., Noura, H., and Ouladsine, M. (2008). Active fault detection and isolation strategy for an unmanned aerial vehicle with redundant flight control surfaces. In *16th Mediterranean Conference on Control and Automation*, pages 1246–1251, Ajaccio-Corsica, France. IEEE.
- [Bellman, 1957] Bellman, R. (1957). *Dynamic programming*. Rand Corporation research study. Princeton University Press.
- [Bertsekas, 2005a] Bertsekas, D. P. (2005a). *Dynamic Programming and Optimal Control: Volume I*. Athena Scientific, Massachusetts, USA.
- [Bertsekas, 2005b] Bertsekas, D. P. (2005b). *Dynamic Programming and Optimal Control: Volume II*. Athena Scientific, Massachusetts, USA.
- [Blackmore et al., 2008] Blackmore, L., Rajamanoharan, S., and Williams, B. C. (2008). Active estimation for jump markov linear systems. *IEEE Transactions on Automatic Control*, 53(10):2223–2236.
- [Blackmore and Williams, 2005] Blackmore, L. and Williams, B. C. (2005). Finite horizon control design for optimal model discrimination. In *Proceedings of the 44th IEEE Conference on Decision and Control, and European Control Conference 2005*, pages 3795–3802, Seville, Spain.

- [Blackmore and Williams, 2006] Blackmore, L. and Williams, B. C. (2006). Finite horizon control design for optimal discrimination between several models. In *Proceedings of the 45th IEEE Conference on Decision and Control*, pages 1147–1152, San Diego, USA.
- [Blanke et al., 2003] Blanke, M., Kinnaert, M., Staroswiecki, M., and Lunze, J. (2003). *Diagnosis and Fault-tolerant Control*. Springer Verlag, Berlin, Germany.
- [Boers and Driessen, 2005] Boers, Y. and Driessen, H. (2005). A multiple model multiple hypothesis filter for Markovian switching systems. *Automatica*, 41(4):709–716.
- [Boyd and Vandenberghe, 2004] Boyd, S. and Vandenberghe, L. (2004). *Convex optimization*. Cambridge university press.
- [Braun, 2003] Braun, J. E. (2003). Load control using building thermal mass. *Journal of Solar Energy Engineering*, 125(3):292–301.
- [Camacho and Bordons, 2004] Camacho, E. F. and Bordons, C. (2004). *Model Predictive Control*. Springer-Verlag.
- [Campbell and Nikoukhah, 2004] Campbell, S. L. and Nikoukhah, R. (2004). *Auxiliary Signal Design for Failure Detection*. Princeton University Press, New Jersey, USA.
- [Chen, 2002] Chen, T. (2002). Application of adaptive predictive control to a floor heating system with a large thermal lag. *Energy and Buildings*, 34(1):45–51.
- [Cho, 2003] Cho, S. (2003). Predictive control of intermittently operated radiant floor heating systems. *Energy Conversion and Management*, 44(8):1333–1342.
- [CPLEX’s webpage,] CPLEX’s webpage. IBM CPLEX. Website. URL: <http://www-01.ibm.com/software/integration/optimization/cplex-optimizer/>.
- [Crassidis and Junkins, 2011] Crassidis, J. and Junkins, J. (2011). *Optimal estimation of dynamic systems*, volume 24. Chapman & Hall.
- [Ding, 2009] Ding, S. (2009). Integrated design of feedback controllers and fault detectors. *Annual reviews in control*, 33(2):124–135.
- [Dounis and Caraiscos, 2009] Dounis, A. and Caraiscos, C. (2009). Advanced control systems engineering for energy and comfort management in a building environment—a review. *Renewable and Sustainable Energy Reviews*, 13(6-7):1246–1261.
- [Dupačová and Sladký, 2002] Dupačová, J. and Sladký, K. (2002). Comparison of multistage stochastic programs with recourse and stochastic dynamic programs with discrete time. *ZAMM-Journal of Applied Mathematics and Mechanics/Zeitschrift für Angewandte Mathematik und Mechanik*, 82(11-12):753–765.

- [Eckerman, 2005] Eckerman, I. (2005). The Bhopal gas leak: Analyses of causes and consequences by three different models. *Journal of loss prevention in the process industries*, 18(4-6):213–217.
- [Esna Ashari et al., 2011] Esna Ashari, A., Nikoukhah, R., and Campbell, S. (2011). Auxiliary signal design for robust active fault detection of linear discrete-time systems. *Automatica*, 47(9):1887–1895.
- [Fair and Campbell, 2009] Fair, M. and Campbell, S. (2009). Active incipient fault detection with more than two simultaneous faults. In *Proceedings of the 2009 IEEE international conference on Systems, Man and Cybernetics*, pages 3322–3327, San Antonio, Texas. IEEE.
- [Ferkl and Široký, 2010] Ferkl, L. and Široký, J. (2010). Ceiling radiant cooling: Comparison of armax and subspace identification modelling methods. *Building and Environment*, 45(1):205–212.
- [Freire et al., 2008] Freire, R., Oliveira, G., and Mendes, N. (2008). Predictive controllers for thermal comfort optimization and energy savings. *Energy and Buildings*, 40(7):1353–1365.
- [Gertler, 1998] Gertler, J. (1998). *Fault Detection and Diagnosis in Engineering Systems*. Taylor & Francis.
- [Gertler and Singer, 1990] Gertler, J. and Singer, D. (1990). A new structural framework for parity equation-based failure detection and isolation. *Automatica*, 26(2):381–388.
- [Ghiaus et al., 2007] Ghiaus, C., Chicinas, A., and Inard, C. (2007). Grey-box identification of air-handling unit elements. *Control engineering practice*, 15(4):421–433.
- [Grünenfelder, 1985] Grünenfelder, W. T. (1985). The use of weather predictions and dynamic programming in the control of solar domestic hot water systems. In *3rd Mediterranean Electrotechnical Conference (Melecon)*, Madrid, Spain.
- [Gustafsson, 2000] Gustafsson, F. (2000). *Adaptive Filtering and Change Detection*. John Wiley & Sons, Chichester, WSX, UK.
- [Hajiyev and Caliskan, 2003] Hajiyev, C. and Caliskan, F. (2003). *Fault Diagnosis and Reconfiguration in Flight Control Systems*. Springer.
- [Han et al., 2010] Han, H., Jeon, Y., Lim, S., Kim, W., and Chen, K. (2010). New developments in illumination, heating and cooling technologies for energy-efficient buildings. *Energy*, 35(6):2647–2653.
- [Hazyuk and Ghiaus, 2010] Hazyuk, I. and Ghiaus, C. (2010). A method of heating systems sizing for discontinuously occupied buildings. In *Proceedings of 10th REHVA World Congress, Clima 2010*.

- [Henze et al., 2004] Henze, G. P., Felsmann, C., and Knabe, G. (2004). Evaluation of optimal control for active and passive building thermal storage. *International Journal of Thermal Sciences*, 43:173–183.
- [House et al., 1999] House, J., Lee, W., and Shin, D. (1999). Classification techniques for fault detection and diagnosis of an air-handling unit. *Transactions - American Society of Heating, Refrigerating and Air-Conditioning Engineers*, 105:1087–1100.
- [House et al., 2001] House, J., Vaezi-Nejad, H., and Whitcomb, J. (2001). An expert rule set for fault detection in air-handling units. *Transactions - American Society of Heating, Refrigerating and Air-Conditioning Engineers*, 107(1):858–874.
- [Hyvärinen, 1996] Hyvärinen, J. (1996). Building optimization and fault diagnosis system concept. In *Building optimization and fault diagnosis source book*. Technical Research Centre of Finland.
- [Isermann, 1984] Isermann, R. (1984). Process fault detection based on modeling and estimation methods—A survey. *Automatica*, 20(4):387–404.
- [Isermann, 2006] Isermann, R. (2006). *Fault-diagnosis systems: an introduction from fault detection to fault tolerance*. Berlin, Heidelberg: Springer-Verlag Berlin Heidelberg.
- [Jacobson and Nett, 1991] Jacobson, C. and Nett, C. (1991). An integrated approach to controls and diagnostics using the four parameter controller. *Control Systems Magazine, IEEE*, 11(6):22–29.
- [Katipamula et al., 2010] Katipamula, S., Armstrong, P. R., Wang, W., Fernandez, N., and Cho, H. (2010). Efficient low-lift cooling with radiant distribution, thermal storage and variable-speed chiller controls. In *Proceedings of 10th REHVA World Congress, Clima 2010*.
- [Katipamula and Brambley, 2005] Katipamula, S. and Brambley, M. (2005). Methods for fault detection, diagnostics, and prognostics for building systems—A review. *HVAC&R Research*, 11(1):3–25.
- [Kerestecioğlu, 1993] Kerestecioğlu, F. (1993). *Change Detection and Input Design in Dynamical Systems*. Research Studies Press, Hertfordshire, Taunton, England.
- [Khosrowjerdi et al., 2004] Khosrowjerdi, M. J., Nikoukhah, R., and Safari-Shad, N. (2004). A mixed $\mathcal{H}_2/\mathcal{H}_\infty$ approach to simultaneous fault detection and control. *Automatica*, 40(2):261–267.
- [Kiefer and Wolfowitz, 1959] Kiefer, J. and Wolfowitz, J. (1959). Optimum designs in regression problems. *The Annals of Mathematical Statistics*, 30(2):pp. 271–294.
- [Kusiak and Li, 2009] Kusiak, A. and Li, M. (2009). Optimal decision making in ventilation control. *Energy*, 34(11):1835–1845.

- [Kusiak and Li, 2010] Kusiak, A. and Li, M. (2010). Reheat optimization of the variable-air-volume box. *Energy*, 35(5):1997–2005.
- [Lee et al., 1996] Lee, W., House, J., Park, C., and Kelly, G. (1996). Fault diagnosis of an air-handling unit using artificial neural networks. *ASHRAE Transactions*, 102(1):540–549.
- [Lee et al., 1997] Lee, W., House, J., and Shin, D. (1997). Fault diagnosis and temperature sensor recovery for an air-handling unit. *Transactions - American Society of Heating, Refrigerating and Air-Conditioning Engineers*, 103:621–633.
- [Liu and Henze, 2006a] Liu, S. and Henze, G. P. (2006a). Experimental analysis of simulated reinforcement learning control for active and passive building thermal storage inventory Part 1 . Theoretical foundation. *Energy and Buildings*, 38:142–147.
- [Liu and Henze, 2006b] Liu, S. and Henze, G. P. (2006b). Experimental analysis of simulated reinforcement learning control for active and passive building thermal storage inventory Part 2 : Results and analysis. *Energy and Buildings*, 38:148–161.
- [Ljung, 1987] Ljung, L. (1987). System identification: Theory for the user. *Prentice Hall, New Jersey*, 7632.
- [Löfberg, 2004] Löfberg, J. (2004). Yalmip : A toolbox for modeling and optimization in MATLAB. In *Proceedings of the CACSD Conference*, Taipei, Taiwan.
- [Ma et al., 2011] Ma, Y., Anderson, G., and Borrelli, F. (2011). A distributed predictive control approach to building temperature regulation. In *American Control Conference (ACC), 2011*, pages 2089–2094, San Francisco, California. IEEE.
- [Ma et al., 2010] Ma, Y., Borrelli, F., Hencsey, B., Coffey, B., Bengesa, S., and Haves, P. (2010). Model predictive control for the operation of building cooling systems. In *American Control Conference (ACC), 2010*, pages 5106–5111, San Francisco, California.
- [Ma et al., 2009] Ma, Y., Borrelli, F., Hencsey, B., Packard, A., and Bortoff, S. (2009). Model Predictive Control of thermal energy storage in building cooling systems. *Proceedings of the 48th IEEE Conference on Decision and Control (CDC) held jointly with 2009 28th Chinese Control Conference*, pages 392–397.
- [Maciejowski and Jones, 2003] Maciejowski, J. and Jones, C. (2003). MPC fault-tolerant flight control case study: Flight 1862. In *5th IFAC Symposium on Fault Detection, Supervision and Safety for Technical Process*, pages 121–126, Washington.
- [McCormick, 1976] McCormick, G. (1976). Computability of global solutions to factorable nonconvex programs: Part I – Convex underestimating problems. *Mathematical Programming*, 10(1):147–175.

- [Mehra, 1974] Mehra, R. (1974). Optimal input signals for parameter estimation in dynamic systems—survey and new results. *IEEE Transactions on Automatic Control*, 19(6):753–768.
- [Montoya et al., 1983] Montoya, R., Howell, W., Bundick, W., Ostroff, A., Hueschen, R., and Belcastro, C. (1983). *Restructurable controls*. NASA conference publication. National Aeronautics and Space Administration, Scientific and Technical Information Branch.
- [Mossolly et al., 2009] Mossolly, M., Ghali, K., and Ghaddar, N. (2009). Optimal control strategy for a multi-zone air conditioning system using a genetic algorithm. *Energy*, 34(1):58–66.
- [Nett et al., 1988] Nett, C., Jacobson, C., and Miller, A. (1988). An integrated approach to controls and diagnostics: The 4-parameter controller. In *Proceedings of the American Control Conference*, pages 824–835, Atlanta.
- [Niemann, 2006] Niemann, H. (2006). A setup for active fault diagnosis. *IEEE Transactions on Automatic Control*, 51(9):1572–1578.
- [Niemann and Stoustrup, 1999] Niemann, H. and Stoustrup, J. (1999). Integration of control and fault detection: Nominal and robust design. In *Proceedings of the IFAC Symposium on Fault Detection*, pages 341–346, Hull, UK.
- [Niemann and Stoustrup, 2006] Niemann, H. and Stoustrup, J. (2006). Active fault diagnosis by temporary destabilization. In *Proceedings of the 6th IFAC Symposium on Fault Detection Supervision and Safety for Technical Processes, Safeprocess*, pages 607–612, Beijing.
- [Nikoukhah and Campbell, 2005] Nikoukhah, R. and Campbell, S. (2005). A multi-model approach to failure detection in uncertain sampled-data systems. *European journal of control*, 11(3):255–268.
- [Nikoukhah and Campbell, 2006] Nikoukhah, R. and Campbell, S. (2006). Auxiliary signal design for active failure detection in uncertain linear systems with a priori information. *Automatica*, 42(2):219–228.
- [Nikoukhah et al., 2010] Nikoukhah, R., Campbell, S., and Drake, K. (2010). An active approach for detection of incipient faults. *International Journal of Systems Science*, 41(2):241–257.
- [Oldewurtel et al., 2008] Oldewurtel, F., Jones, C., and Morari, M. (2008). A tractable approximation of chance constrained stochastic MPC based on affine disturbance feedback. In *Proceedings of the 47th IEEE Conference on Decision and Control*, pages 4731–4736, Cancun, Mexico. IEEE.
- [Oldewurtel et al., 2010] Oldewurtel, F., Ulbig, A., Parisio, A., Andersson, G., and Morari, M. (2010). Reducing peak electricity demand in building climate control using real-time pricing and model predictive control. In *Proceedings of the 49th*

IEEE Conference on Decision and Control (CDC), pages 1927–1932, Atlanta. IEEE.

- [Overschee and Moor, 1993] Overschee, P. V. and Moor, B. D. (1993). Subspace algorithms for the stochastic identification problem. *Automatica*, 29(3):649–660.
- [Patton et al., 1989] Patton, R., Frank, P., and Clark, R. (1989). *Fault diagnosis in dynamic systems – Theory and application*. Prentice Hall, London, UK.
- [Perez-Lombard et al., 2008] Perez-Lombard, L., Ortiz, J., and Pout, C. (2008). A review on buildings energy consumption information. *Energy and buildings*, 40(3):394–398.
- [Poulsen and Niemann, 2008] Poulsen, N. and Niemann, H. (2008). Active fault diagnosis based on stochastic tests. *International Journal of Applied Mathematics and Computer Science*, 18(4):487–496.
- [Powell, 2007] Powell, W. (2007). *Approximate Dynamic Programming: Solving the curses of dimensionality*. Wiley-Blackwell.
- [Prékopa, 2010] Prékopa, A. (2010). *Stochastic Programming*. Springer, Amsterdam, The Netherlands.
- [Prívará et al., 2011] Prívará, S., Široký, J., Ferkl, L., and Cigler, J. (2011). Model predictive control of a building heating system: The first experience. *Energy and Buildings*, 43(2):564–572.
- [Punčochář et al., 2009] Punčochář, I., Král, L., and Šimandl, M. (2009). Active fault detection for neural network based control of non-linear stochastic systems. In *Fault Detection, Supervision and Safety of Technical Processes*, pages 125–130, Barcelona, Spain. IFAC, International Federation of Automatic Control.
- [Punčochář and Šimandl, 2008] Punčochář, I. and Šimandl, M. (2008). Active fault detection and dual control in multiple model framework. In *Proceedings of the 17th IFAC World Congress*, pages 7227–7232, Seoul, Korea.
- [Punčochář and Šimandl, 2009] Punčochář, I. and Šimandl, M. (2009). A feasible design of active detector and input signal generator. In *Preprints of the 7th IFAC Symposium on Fault Detection, Supervision and Safety of Technical Processes*, pages 579–584, Barcelona, Spain.
- [Punčochář et al., 2010] Punčochář, I., Široký, J., and Šimandl, M. (2010). Optimal decision making for control. In *Proceedings of the Conference on Control and Fault-Tolerant Systems*, pages 660–665, Nice, France.
- [Qian and Chen, 1996] Qian, S. and Chen, D. (1996). *Joint Time-Frequency Analysis: Method and Application*. Prentice Hall.
- [Qin and Wang, 2005] Qin, J. and Wang, S. (2005). A fault detection and diagnosis strategy of VAV air-conditioning systems for improved energy and control performances. *Energy and buildings*, 37(10):1035–1048.

- [Randall, 1987] Randall, R. B. (1987). *Frequency Analysis*. Bruel & Kjaer, 3rd edition.
- [Rawlings and Mayne, 2009] Rawlings, J. and Mayne, D. (2009). *Model Predictive Control: Theory and Design*. Nob Hill Publishing.
- [Rijksen et al., 2010] Rijksen, D. O., Wisse, C. J., and Schijndel, A. W. M. V. (2010). Reducing peak requirements for cooling by using thermally activated building systems. *Energy and Buildings*, 42(3):298–304.
- [Schein et al., 2006] Schein, J., Bushby, S., Castro, N., and House, J. (2006). A rule-based fault detection method for air handling units. *Energy and buildings*, 38(12):1485–1492.
- [Shapiro and Philpott, 2007] Shapiro, A. and Philpott, A. (2007). A tutorial on stochastic programming. *Manuscript. Available at www2.isye.gatech.edu/ashapiro/publications.html*.
- [Šimandl and Duník, 2009] Šimandl, M. and Duník, J. (2009). Derivative-free estimation methods: New results and performance analysis. *Automatica*, 45(7):1749–1757.
- [Šimandl et al., 2006] Šimandl, M., Královec, J., and Söderström, T. (2006). Advanced point-mass method for nonlinear state estimation. *Automatica*, 42(7):1133–1145.
- [Šimandl and Punčochář, 2006] Šimandl, M. and Punčochář, I. (2006). Closed loop information processing strategy for optimal fault detection and control. In *Preprints of the 14th IFAC Symposium on System Identification*, pages 487–492, Newcastle, Australia.
- [Šimandl and Punčochář, 2007] Šimandl, M. and Punčochář, I. (2007). Unified solution of optimal active fault detection and optimal control. In *Preprints of the 26th American Control Conference*, pages 3222–3227, New York, USA.
- [Šimandl and Punčochář, 2009] Šimandl, M. and Punčochář, I. (2009). Active fault detection and control: Unified formulation and optimal design. *Automatica*, 45(9):2052–2059.
- [Šimandl et al., 2005] Šimandl, M., Punčochář, I., and Královec, J. (2005). Rolling horizon for active fault detection. In *Proceedings of the 44th IEEE Conference on Decision and Control, and European Control Conference 2005*, pages 3789–3794, Seville, Spain.
- [Šimandl et al., 2009] Šimandl, M., Široký, J., and Punčochář, I. (2009). Likelihood function and threshold estimation for CUSUM test application. In *Proceedings of the 28th IASTED International Conference on Modelling, Identification, and Control*, pages 38–43, Innsbruck. Acta Press.

- [Šimandl et al., 2011] Šimandl, M., Široký, J., and Punčochář, I. (2011). New special cases of general active change detection and control problem. In *Proceedings of the 18th IFAC World Congress*, pages 4260–4265, Milano, Italy. IFAC.
- [Simon, 2006] Simon, D. (2006). *Optimal State Estimation: Kalman, H Infinity, and Nonlinear Approaches*. Wiley-Interscience.
- [Široký et al., 2012] Široký, Punčochář, I., J., and Šimandl (2012). Active fault detection and constrained control of air handling unit. In *Proceedings of the 8th IFAC Symposium on Fault Detection, Supervision and Safety of Technical Processes*, pages 43–48, National Autonomous University of Mexico, Mexico City, Mexico. IFAC.
- [Široký et al., 2011a] Široký, J., Oldewurtel, F., Cigler, J., and Prívar, S. (2011a). Experimental analysis of model predictive control for an energy efficient building heating system. *Applied Energy*, 88(9):3079–3087.
- [Široký and Šimandl, 2007] Široký, J. and Šimandl, M. (2007). The multiple model approach to fault detection with result verification. In *Proceedings of the 1st Young Researchers Conference on Applied Sciences*, pages 224–229, Pilsen, Czech Republic. University of West Bohemia.
- [Široký and Šimandl, 2008] Široký, J. and Šimandl, M. (2008). The CUSUM parameters design in fault detection. In *Proceedings of the Process Control 2008*, Kouty nad Desnou, Czech Republic. University of Pardubice.
- [Široký et al., 2011b] Široký, J., Šimandl, M., Axehill, D., and Punčochář, I. (2011b). An optimization approach to resolve the competing aims of active fault detection and control. In *Proceedings of the 50th IEEE Conference on Decision and Control and European Control Conference (CDC-ECC)*, pages 3712–3717, Orlando. IEEE.
- [SNOPT's webpage,] SNOPT's webpage. SNOPT. Website. URL: http://www.sbsi-sol-optimize.com/asp/sol_products_snopt_desc.htm.
- [Snyder and Newell, 1990] Snyder, M. and Newell, T. (1990). Cooling cost minimization using building mass for thermal storage. *Transactions - American Society of Heating, Refrigerating and Air-Conditioning Engineers*, 96(2):830–838.
- [Spindler and Norford, 2009] Spindler, H. and Norford, L. (2009). Naturally ventilated and mixed-mode buildings—Part II: Optimal control. *Building and Environment*, 44(4):750–761.
- [Stigler, 1974] Stigler, S. M. (1974). Gergonne's 1815 paper on the design and analysis of polynomial regression experiments. *Historia Mathematica*, 1(4):431–447.
- [Stoustrup et al., 1997] Stoustrup, J., Grimble, M. J., and Niemann, H. H. (1997). Design of integrated systems for control and detection of actuator/sensor faults. *Sensor Review*, 17(2):138–149.

- [Trojanova et al., 2009] Trojanova, J., Vass, J., Macek, K., Rojicek, J., and Stluka, P. (2009). Fault diagnosis of air handling units. In *Proceedings of the 7th IFAC Symposium on Fault Detection, Supervision and Safety of Technical Processes*, pages 366–371, Barcelona, Spain.
- [Tyler and Morari, 1994] Tyler, M. and Morari, M. (1994). Optimal and robust design of integrated control and diagnostic modules. In *Proceedings of the American Control Conference, 1994*, volume 2, pages 2060–2064, Baltimore. IEEE.
- [Uosaki and Hatanaka, 2004] Uosaki, K. and Hatanaka, T. (2004). Optimal auxiliary input design for fault detection based on kullback divergence. In *Proceedings of the 5th Asian Control Conference*, volume 1, pages 428–434, Melbourne, Australia. IEEE.
- [Vanhoudt et al., 2010] Vanhoudt, D., de Ridder, F., Desmedt, J., and van Bael, J. (2010). Controller for optimal cost operation of a borehole thermal energy storage system. In *Proceedings of the 10th REHVA World Congress, Clima 2010*, Antalya, Turkey.
- [Venkatasubramanian et al., 2003] Venkatasubramanian, V., Rengaswamy, R., Yin, K., and Kavuri, S. N. (2003). A review of process fault detection and diagnosis, Part I: Quantitative model-based methods. *Computers and Chemical Engineering*, 27(3):293–311.
- [Wald, 1945] Wald, A. (1945). Sequential tests of statistical hypotheses. *The Annals of Mathematical Statistics*, 16(2):117–186.
- [Wang, 1999] Wang, S. (1999). Dynamic simulation of building VAV air-conditioning system and evaluation of EMCS on-line control strategies. *Building and Environment*, 34(6):681–705.
- [Willsky, 1976] Willsky, A. (1976). A survey of design methods for failure detection in dynamic systems. *Automatica*, 12(6):601–611.
- [Wong et al., 2005] Wong, J., Li, H., and Wang, S. (2005). Intelligent building research: a review. *Automation in Construction*, 14(1):143–159.
- [Xu et al., 2009] Xu, X., Wang, S., Sun, Z., and Xiao, F. (2009). A model-based optimal ventilation control strategy of multi-zone VAV air-conditioning systems. *Applied Thermal Engineering*, 29(1):91–104.
- [Žampa et al., 2004] Žampa, P., Mošna, J., and Prautsch, P. (2004). Some consequences of new approach to system theory in optimal control. In *Proceedings of the European Meeting on Cybernetics and System Research*, Vienna, Austria.
- [Zarrop, 1979] Zarrop, M. (1979). *Optimal experiment design for dynamic system identification*, volume 21 of *Lecture notes in control and information sciences*. Springer.

- [Zhang, 1989] Zhang, X. (1989). *Auxiliary Signal Design in Fault Detection and Diagnosis*. Springer.
- [Zhang and Jiang, 2008] Zhang, Y. and Jiang, J. (2008). Bibliographical review on reconfigurable fault-tolerant control systems. *Annual Reviews in Control*, 32(2):229–252.

Author's publications

Cigler, J., Široký, J., Kulvejt, M., Chlupáč, M., and Gyalistras, D. (2011). Web services based data acquisition from a process database. In *Proceedings of the 19th Annual Conference Proceedings: Technical Computing Prague 2011*, pages 28–33, Prague, Czech Republic.

Cigler, J., Tomáško, P., and Široký, J. (2013). BuildingLab: a tool to analyze performance of model predictive controllers for buildings. *Energy and Buildings*, 57:34 – 41.

Ferkl, L. and Široký, J. (2010). Ceiling radiant cooling: Comparison of armax and subspace identification modelling methods. *Building and Environment*, 45(1):205–212.

Ferkl, L., Široký, J., and Prívará, S. (2010). Model predictive control of buildings: The efficient way of heating. In *Proceedings of the IEEE International Conference on Control Applications (CCA)*, pages 1922–1926, Yokohama, Japan. IEEE.

Hrúz, M., Široký, J., and Mañas, D. (2010a). Knoop hardness measurement using computer vision. In *Proceedings of the 21st International DAAAM Symposium "Intelligent Manufacturing & Automation: Focus on Interdisciplinary Solutions"*, volume 21, pages 537–538, Zadar, Croatia.

Hrúz, M., Široký, J., and Mañas, D. (2010b). Robust image processing technique for knoop hardness measurement. In *Proceedings of the IMEKO 17th TC-4, 3rd TC-19 Symposium and Workshop IWADC*, Košice, Slovakia. Technical University of Kosice.

Prívará, S., Široký, J., Ferkl, L., and Cigler, J. (2011). Model predictive control of a building heating system: The first experience. *Energy and Buildings*, 43(2):564–572.

Punčochář, I., Široký, J., and Šimandl, M. (2010). Optimal decision making for control. In *Proceedings of the Conference on Control and Fault-Tolerant Systems*, pages 660–665, Nice, France.

Šimandl, M., Široký, J., and Punčochář, I. (2009). Likelihood function and threshold estimation for CUSUM test application. In *Proceedings of the 28th IASTED International Conference on Modelling, Identification, and Control*, pages 38–43, Innsbruck. Acta Press.

- Šimandl, M., Široký, J., and Punčochář, I. (2011). New special cases of general active change detection and control problem. In *Proceedings of the 18th IFAC World Congress*, pages 4260–4265, Milano, Italy. IFAC.
- Široký, Punčochář, I., J., and Šimandl (2012). Active fault detection and constrained control of air handling unit. In *Proceedings of the 8th IFAC Symposium on Fault Detection, Supervision and Safety of Technical Processes*, pages 43–48, National Autonomous University of Mexico, Mexico City, Mexico. IFAC.
- Široký, J. (2009). Úspory energie pomocí simulace vývoje vnitřních teplot využívající informací o předpovědi počasí. In *Proceedings of the 20th Konference Vytápění*, Třebon, Czech Republic. Společnost pro techniku prostředí.
- Široký, J. and Ferkl, L. (2009). Model of a hot water full circulation mode in a building. In *Proceedings of The 7th IEEE International Conference on Control and Automation*, pages 585–590, Christchurch, New Zeland. IEEE.
- Široký, J., Ferkl, L., and Lain, M. (2008). Identifikace otopného systému Crittall pro funkci chlazení místností fakulty strojní ČVUT v Praze. In *Proceedings of the Simulace budov a techniky prostředí*, pages 143–147, Brno, Czech Republic. IBPSA-CZ.
- Široký, J., Ferkl, L., and Lain, M. (2009). Identifikace otopného systému Crittall pro funkci chlazení místností fakulty strojní ČVUT v Praze. *Vytápění, větrání, instalace*, 18:137–140.
- Široký, J., Kubeček, J., and Kudera, P. (2011a). Vyhodnocení úspor dosažených prediktivním řízením crittallového vytápění. *Vytápění, větrání, instalace*, 20:228–231.
- Široký, J. and Lain, M. (2010). Air conditioning units fault detection methods. In *Proceedings of the Konference Klimatizace a větrání 2010*, pages 137–142, Prague, Czech Republic. Společnost pro techniku prostředí.
- Široký, J., Oldewurtel, F., Cigler, J., and Prívar, S. (2011b). Experimental analysis of model predictive control for an energy efficient building heating system. *Applied Energy*, 88(9):3079–3087.
- Široký, J., Prívar, S., and Ferkl, L. (2010). Model predictive control of building heating system. In *Proceedings of the Clima 2010 (10th REHVA World Congress)*, Antalya, Turkey. Turkish Society of HVAC and Sanitary Engineers.
- Široký, J. and Šimandl, M. (2007). The multiple model approach to fault detection with result verification. In *Proceedings of the 1st Young Researchers Conference on Applied Sciences*, pages 224–229, Pilsen, Czech Republic. University of West Bohemia.
- Široký, J. and Šimandl, M. (2008). The CUSUM parameters design in fault detection. In *Proceedings of the Process Control 2008*, Kouty nad Desnou, Czech Republic. University of Pardubice.

Široký, J., Šimandl, M., Axehill, D., and Punčochář, I. (2011c). An optimization approach to resolve the competing aims of active fault detection and control. In *Proceedings of the 50th IEEE Conference on Decision and Control and European Control Conference (CDC-ECC)*, pages 3712–3717, Orlando. IEEE.