

MODELLING OF TWO-STAGE FREQUENCY CONVERTER USING COMPLEX CONJUGATED MAGNITUDES- AND ORTHOGONAL PARK/CLARKE TRANSFORMATION

ING. MARIANA BEŇOVÁ, PHD.
 PROF. ING. BRANISLAV DOBRUCKÝ, PHD.
 ING. RÓBERT ŠUL

Abstract: *The paper deals with mathematical modelling of two-stage frequency converter. There are used two special methods of investigation. The first one, method of complex conjugated amplitude, is used for steady-state investigation. The second one, orthogonal Park/Clarke transformation is suitable for investigation of three-phase electric circuits. The combination of both methods is very useful for analysis of three-phase electric motors in steady-state condition.*

Key words: *Complex conjugated magnitudes, orthogonal Park/Clarke transformation, electric machine, frequency converter*

INTRODUCTION

Method of complex conjugated magnitudes has been introduced by Takeuchi [1] for analysis of converter circuit supplying electric machines in steady-state. The principle is based on substitution of trigonometric function by exponential one with complex argument. After determination of investigated variable in complex form, the variable can be than transformed back into time domain. Regarding to non-sinusoidal time waveforms of converter quantities the Fourier analysis is used for variables as the first step.

Method of orthogonal transformation for electrical quantities was introduced by Park [2] for three-phase electric machines. The method makes it possible to transform symmetrical 3-phase system into equivalent two-phase orthogonal system. This transformation decreases number of differential equations (from 3 to 2), and removes variable coefficients in the equations. Besides, trajectories of the quantities in complex Gauss plane denote themselves by six-side symmetry, thus the steady-state quantities can be calculated in only one sixth of time period. Clarke's multiplicative transformation constant (equal $2/3$) provides the invariances of voltage and current quantities in the both coordinating systems.

The combination of both methods is very useful for analysis of three-phase electric motors in steady-state

condition: constant angular speed, and when operator d/dt in its dynamical model is substituted by operator $j \cdot \omega \cdot t$. Then one can investigate the effect of individual harmonic components on motor properties.

1 ELECTRICAL AND MATHEMATICAL MODEL OF 2-STAGE FREQUENCY CONVERTER

Scheme of the 2-stage converter is shown in Fig. 1. It comprises of two semiconductor type converters:

- single-phase voltage inverter as the first stage,
- three-phase matrix converter or cycloconverter as the second stage.

The first stage operates with constant voltage U_0 and fixed frequency f_0 . The second one supplies passive $R-L$ or active load (for example electric motor) with variable output frequency and which is much lesser then frequency of AC interlink between stages.

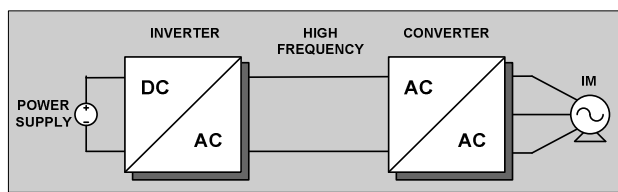

Fig. 1: Overall schematic diagram of 2-stage 3phase DC/AC/AC converter

1.1 Three-phase current inverter

Considering rectangular form of the phase-current length of $2\pi/3$ radians with I_0 equal U_0/R , the scheme can be reconfigured to the scheme of three-phase current inverter with R - L load [2], Fig. 2.

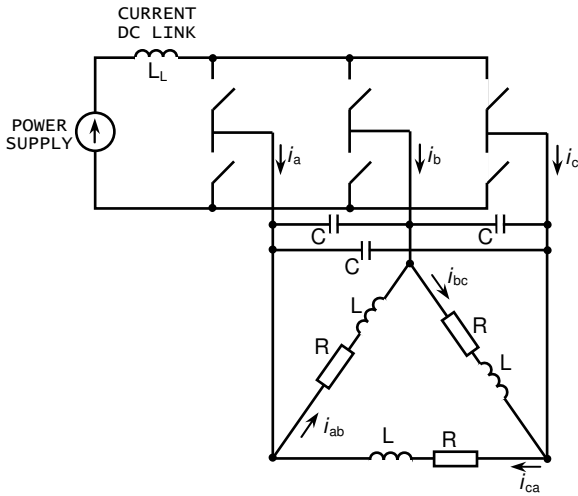

Fig. 2: Transfigured scheme of three-phase current inverter with R - L load in delta connection

The output phase current of three-phase current inverter in rectangular form (Fig.3) can be expressed by Fourier series:

$$i(t) = \frac{4I_0}{\pi} \sum_{\nu=0}^{\infty} \frac{\cos\left((2\nu+1)\frac{\pi}{6}\right)}{2\nu+1} \sin(2\nu+1)\omega t \quad (1)$$

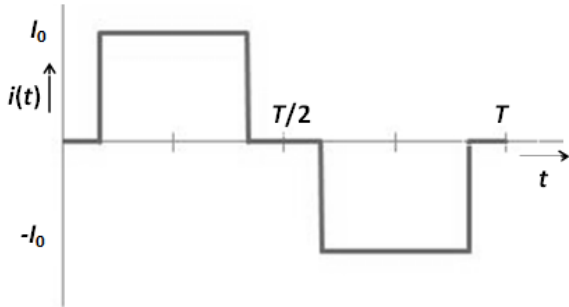

Fig. 3: Rectangular pulse time-waveform of output phase current of the inverter (i_a)

Based on definition of complex-time vector by Park [2] the real- and imaginary parts of the vector can be obtained:

$$\underline{i}(t) = \frac{2}{3} [\underline{i}_a(t) + \underline{a} \underline{i}_b(t) + \underline{a}^2 \underline{i}_c(t)] = i_\alpha(t) + j i_\beta(t), \quad (2)$$

under considering sum of phase currents to be zero. Then

$$i_\alpha(t) = \frac{1}{3} [2i_a(t) - i_b(t) - i_c(t)] = i_a(t), \quad (3a)$$

$$i_\beta(t) = \frac{\sqrt{3}}{3} [i_b(t) - i_c(t)]. \quad (3b)$$

Current of a -phase of the inverter then will be more simply than that of (1):

$$i_a(t) = i_\alpha(t) = \frac{4I_0}{\pi} \sum_{\nu=0}^{\infty} \frac{\cos\left((2\nu+1)\frac{\pi}{6}\right)}{2\nu+1} \sin(2\nu+1)\omega t \quad (4)$$

Current of b -phase lags the current of a -phase, thus:

$$i_b(t) = \frac{4I_0}{\pi} \sum_{\nu=0}^{\infty} \frac{\cos\left((2\nu+1)\frac{\pi}{6}\right)}{2\nu+1} \sin(2\nu+1)\left(\omega t - \frac{2\pi}{3}\right) \quad (5)$$

Imaginary part of the complex-time vector by Park can be

$$\begin{aligned} \sqrt{3} i_\beta(t) &= i_b(t) - i_c(t) = \\ &= \frac{8I_0}{\pi} \sum_{\nu=0}^{\infty} \frac{\cos^2\left((2\nu+1)\frac{\pi}{6}\right) \cdot \sin\left[(2\nu+1)\left(\omega t - \frac{\pi}{2}\right)\right]}{2\nu+1} \end{aligned} \quad (6)$$

Next one can obtain voltages between phases using complex magnitudes method for R - L load.

In practise applications of current inverter can be preferable used trapezoidal time-waveform of phase current, Fig.4. The main reason of it is small number of harmonic components (in special case less than 5%). It can be expressed similarly by Fourier series:

$$i(t) = i_a(t) = \frac{4I_0}{\pi} \sum_{\nu=0}^{\infty} \frac{\sin\left((2\nu+1)\frac{\pi}{6}\right)}{\left(\frac{\pi}{6}\right)^2 (2\nu+1)^2} \sin(2\nu+1)\omega t \quad (7)$$

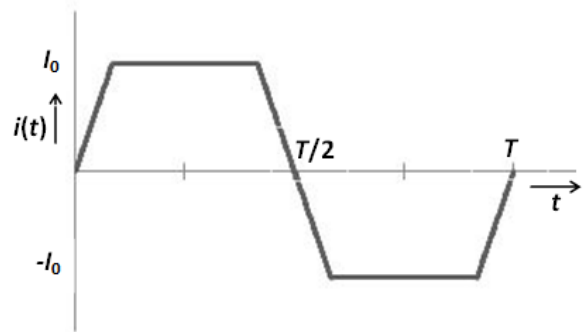

Fig. 4: Trapezoidal pulse time-waveform of output phase current of the inverter (i_a)

Current of b -phase and c -phase lags the current of a -phase, thus:

$$i_b(t) = \frac{24I_0}{\pi^2} \sum_{\nu=0}^{\infty} \frac{\sin\left((2\nu+1)\frac{\pi}{6}\right)}{(2\nu+1)^2} \sin(2\nu+1)\left(\omega t - \frac{2\pi}{3}\right) \quad (8)$$

$$i_c(t) = \frac{24I_0}{\pi^2} \sum_{\nu=0}^{\infty} \frac{\sin\left((2\nu+1)\frac{\pi}{6}\right)}{(2\nu+1)^2} \sin(2\nu+1)\left(\omega t + \frac{2\pi}{3}\right) \quad (9)$$

The real- and imaginary parts of the complex-time vector by Park can be

$$i_\alpha(t) = i_a(t) = \frac{24I_0}{\pi^2} \sum_{\nu=0}^{\infty} \frac{\sin\left((2\nu+1)\frac{\pi}{6}\right)}{(2\nu+1)^2} \sin(2\nu+1)\omega t \quad (10)$$

$$\begin{aligned} \sqrt{3} i_\beta(t) &= i_b(t) - i_c(t) = \\ &= \frac{24I_0}{\pi^2} \sum_{\nu=0}^{\infty} \frac{\sin 2\left((2\nu+1)\frac{\pi}{6}\right)}{(2\nu+1)^2} \cdot \sin(2\nu+1)\left(\omega t + \frac{3\pi}{2}\right) \quad (11) \end{aligned}$$

Similarly the difference of phase-currents $i_a - i_b$ will be:

$$\begin{aligned} i_a(t) - i_b(t) &= \\ &= \frac{24I_0}{\pi^2} \sum_{\nu=0}^{\infty} \frac{\sin 2(2\nu+1)\frac{\pi}{6}}{(2\nu+1)^2} \cdot \sin(2\nu+1)\left(\omega t + \frac{\pi}{6}\right) \quad (12) \end{aligned}$$

Since

$$\begin{aligned} i_a(t) &= i_{ab}(t) - i_{ca}(t) = \\ &= \left(\frac{1}{R + j(2\nu+1)\omega L} + j(2\nu+1)\omega C \right) (u_{ab}(t) - u_{bc}(t)) \quad (13) \end{aligned}$$

and

$$i_a(t) - i_b(t) = \frac{[(u_{ab}(t) - u_{ca}(t)) - (u_{bc}(t) - u_{ab}(t))]}{R + j(2\nu+1)\omega L} \quad (14)$$

$$\frac{1}{(1 - (2\nu+1)^2 \omega^2 LC) + j(2\nu+1)\omega RC}$$

with

$$u_{ab}(t) + u_{bc}(t) + u_{ca}(t) = 0 \quad (15)$$

then

$$i_a(t) - i_b(t) = 3 \cdot \frac{u_{ab}(t)}{R + j(2\nu+1)\omega L} \cdot \frac{1}{(1 - (2\nu+1)^2 \omega^2 LC) + j(2\nu+1)\omega RC} \quad (16)$$

Line to line voltage u_{ab} then will be

$$\begin{aligned} u_{ab}(t) &= \\ &= \frac{R + j(2\nu+1)\omega L}{(1 - (2\nu+1)^2 \omega^2 LC) + j(2\nu+1)\omega RC} \cdot \frac{i_a(t) - i_b(t)}{3} \quad (17) \end{aligned}$$

and using Euler relations voltage can be expressed as

$$\begin{aligned} u_{ab}(t) &= \frac{N_{(2\nu+1)} \cdot e^{j\varphi_{N(2\nu+1)}}}{D_{(2\nu+1)} \cdot e^{j\varphi_{D(2\nu+1)}}} \cdot \frac{i_a(t) - i_b(t)}{3} = \\ &= \frac{8I_0}{\pi^2} \sum_{\nu=0}^{\infty} \frac{\sin 2n \frac{\pi}{6}}{n^2} \cdot \frac{N_n e^{j\varphi_{Nn}}}{D_n e^{j\varphi_{Dn}}} \cdot \frac{e^{jn\left(\omega t - \frac{2\pi}{3}\right)} + e^{-jn\left(\omega t - \frac{2\pi}{3}\right)}}{2} \quad (18) \end{aligned}$$

where: $n = (2\nu+1)$

$N_{(2\nu+1)} = N_n$ - module of complex impedance

numerator $(= \sqrt{R^2 + ((2\nu+1)\omega L)^2})$,

$D_{(2\nu+1)} = D_n$ - module of complex impedance

denominator $(= \sqrt{(1 - (2\nu+1)^2 \omega^2 LC)^2 + ((2\nu+1)\omega RC)^2})$,

$\varphi_{N(2\nu+1)} = \varphi_{Nn} = \arctan \frac{(2\nu+1)\omega L}{R}$,

$\varphi_{D(2\nu+1)} = \varphi_{Dn} = \arctan \frac{(2\nu+1)\omega RC}{(1 - (2\nu+1)^2 \omega^2 LC)}$

This can also be written in complex conjugated form

$$u_{ab}(t) = \frac{1}{\sqrt{2}} \sum_{\nu=0}^{\infty} \left(\underline{U}_{ab_n} e^{jn\omega t} + \underline{U}_{ab_n}^* e^{-jn\omega t} \right) \quad (19)$$

and finally

$$u_{ab}(t) = \frac{4I_0}{\pi^2} \sum_{\nu=0}^{\infty} \frac{\sin 2n \frac{\pi}{6}}{n^2} \cdot \frac{N_n}{D_n} \cdot \sin\left(n\omega t + \frac{3\pi}{2} + \varphi_{Nn} - \varphi_{Dn}\right) \quad (20)$$

1.2 Three-phase voltage inverter

The scheme of three-phase voltage inverter with IM motor load [3] is in Fig. 5, whereas commutating capacitors could be omitted because of switches of inverter are switch-off capability. Control of such system is described in greater detail in [4].

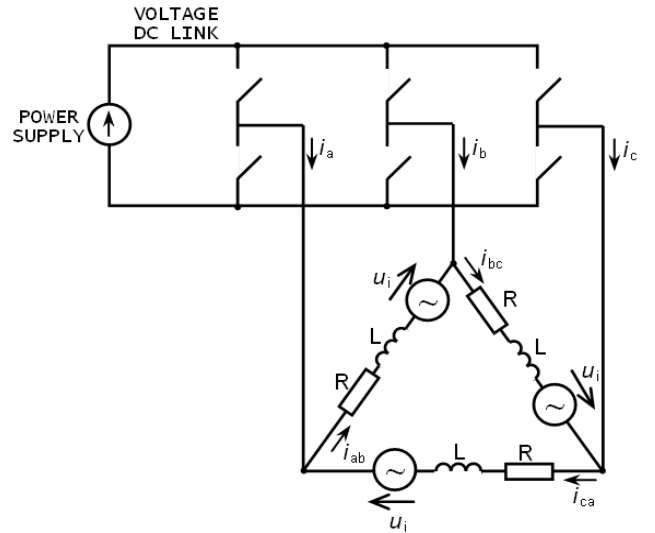

Fig. 5: Transfigured scheme of three-phase voltage inverter with IM motor load in delta connection

The phase voltage of the three-phase voltage inverter (Fig.6) can be expressed by Fourier series and using complex magnitudes method the voltage will be:

$$u(t) = \frac{4U_0}{\pi} \sum_{\nu=0}^{\infty} \frac{\sin\left((2\nu+1)\frac{\pi}{3}\right) \cdot \cos\left[(2\nu+1)\left(\omega t - \frac{\pi}{3}\right)\right]}{2\nu+1} \quad (21)$$

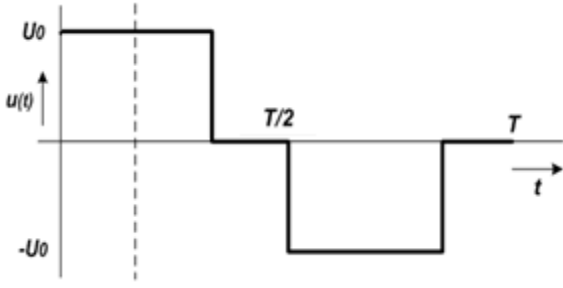

Fig.6: Rectangular pulse time-waveform of single phase of three phase's inverter voltage

Based on definition of complex-time vector by Park [2] the real- and imaginary parts of the vector can be obtained (by eq. 2-3):

$$u_{\alpha}(t) = u_a(t) = \frac{4U_0}{\pi} \sum_{\nu=0}^{\infty} \frac{\sin\left((2\nu+1)\frac{\pi}{3}\right) \cdot \cos\left[(2\nu+1)\left(\omega t - \frac{\pi}{3}\right)\right]}{2\nu+1}, \quad (22)$$

$$\sqrt{3} u_{\beta}(t) = u_b(t) - u_c(t) = -\frac{8U_0}{\pi} \sum_{\nu=0}^{\infty} \frac{\sin^2\left((2\nu+1)\frac{\pi}{3}\right) \cdot \sin\left[(2\nu+1)\left(\omega t + \frac{2\pi}{3}\right)\right]}{2\nu+1} \quad (23)$$

The difference of phase-voltages $u_a(t) - u_b(t)$ then similarly will be:

$$u_a(t) - u_b(t) = -\frac{8U_0}{\pi} \sum_{\nu=0}^{\infty} \frac{\sin^2\left((2\nu+1)\frac{\pi}{3}\right) \cdot \sin\left[(2\nu+1)\left(\omega t - \frac{2\pi}{3}\right)\right]}{2\nu+1} \quad (24)$$

Since

$$u_a(t) - u_b(t) = u_i + (R + j(2\nu+1)\omega L) \cdot [(i_{ab}(t) - i_{ca}(t)) - (i_{bc}(t) - i_{ab}(t))] \quad (25)$$

and $i_{ab}(t) + i_{bc}(t) + i_{ca}(t) = 0$ then

$$u_a(t) - u_b(t) = u_i + 3 \cdot i_{ab}(t) \cdot (R + j(2\nu+1)\omega L) \quad (26)$$

Load current i_{ab} then will be

$$i_{ab}(t) = \frac{u_a(t) - u_b(t) - u_i}{3 \cdot (R + j(2\nu+1)\omega L)} = \frac{u_a(t) - u_b(t) - u_i}{3 \cdot |Z_{(2\nu+1)}| e^{j\varphi_{2\nu+1}}} \quad (27)$$

After substituting $u_a(t) - u_b(t)$ by (26) the current can be expressed as:

$$i_{ab}(t) = \quad (28)$$

$$\begin{aligned} &= \sum_{\nu=0}^{\infty} \frac{1}{3 \cdot |Z_n|} \left(-\frac{8U_0}{\pi} \cdot \frac{\sin^2\left(n\frac{\pi}{3}\right)}{n} \cdot \sin\left[n\left(\omega t - \frac{2\pi}{3}\right)\right] - u_i \right) = \\ &= \sum_{\nu=0}^{\infty} \frac{1}{3} \left(-\frac{8U_0}{\pi} \cdot \frac{\sin^2\left(n\frac{\pi}{3}\right)}{n|Z_n|} \cdot \sin\left[n\left(\omega t - \frac{2\pi}{3} - \varphi_n\right)\right] - \frac{u_i}{|Z_n|} \right) \\ i_{ab}(t) &= -\sum_{\nu=0}^{\infty} \frac{u_i}{3 \cdot |Z_n|} - \\ &= -\frac{4U_0}{3\pi} \sum_{\nu=0}^{\infty} \frac{\sin^2\left(n\frac{\pi}{3}\right)}{n} \cdot \frac{1}{|Z_n|} \cdot \left(e^{jn\left(\omega t - \frac{2\pi}{3}\right)} - e^{-jn\left(\omega t - \frac{2\pi}{3}\right)} \right), \end{aligned} \quad (29)$$

where $n = 2\nu + 1$,

$$|Z_n| = |Z_{(2\nu+1)}| = \sqrt{R^2 + (2\nu+1)^2 \omega^2 L^2},$$

$$\varphi_n = \varphi_{(2\nu+1)} = \arctan \frac{(2\nu+1)\omega L}{R}.$$

Based on above mentioned equation (22)-(29) the following simulations in Gauss plane and in time-domain have been programmed in Matlab programming environment. Parameters of the circuit: $R = 1 \text{ Ohm}$, $L = 5 \text{ mH}$, $U_0 = 100 \text{ V}$, $u_i = f(\omega_i)$.

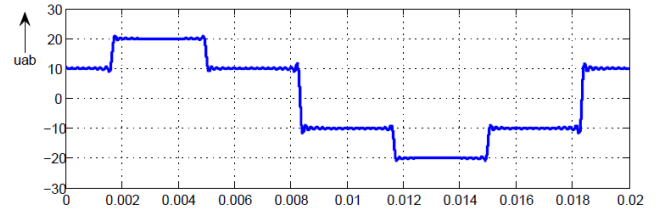

Fig. 7: Time waveform of terminal voltage u_{ab} of the inverter

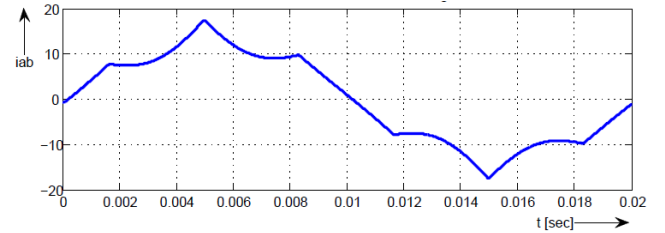

Fig. 8: Phase current i_{ab} of the IM during run

1.3 Single-phase voltage inverter with PWM

In practise applications of voltage inverter three-phase connection consist of three single-phase half-bridge connection (see Fig. 9a). The classical unipolar pulse-width modulation (PWM) cannot be used in this case, due to impossibility to create zero voltage intervals upon the load.

So, only bipolar PWM can be implicated for right operation of the half-bridge converter, Fig. 9b.

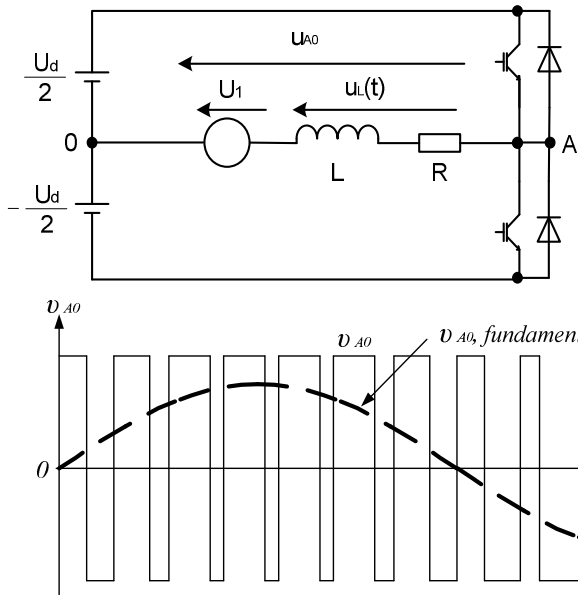

Fig. 9: Single-phase half-bridge inverter (a) with PWM (b)

Switching-pulse-width can be determined based on equivalence of average values of reference waveform and resulting average value of positive and negative switching pulses during switching period, Fig. 10.

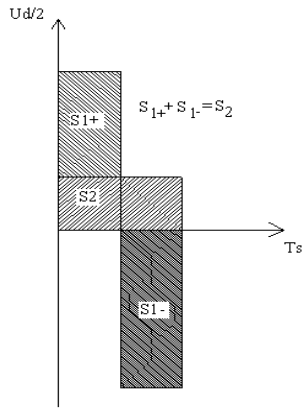

Fig. 10: Equivalence of average values of the reference- and switching functions (pulses)

Considering the equivalence described above one can write following relation:

$$U_{av+} = \frac{t_{1a}}{T_s}, \quad U_{av-} = \frac{t_{2a}}{T_s}, \quad (30a)$$

$$t_{1a} + t_{2a} = T_s, \quad (30b)$$

$$U_{av\sin} = U_{av+} - U_{av-}, \quad (30c)$$

$$t_{1a} = \frac{T_s \times (U_{av\sin} + U)}{2U}, \quad (30d)$$

where : t_{1a} is width of positive pulses, t_{2a} is width of negative pulses, U_{av+} is average value of positive impulse, U_{av-} is average value of negative impulse,

$U_{av\sin}$ is average value of reference sinusoidal waveform and T_s is switching period of PWM modulation.

Harmonic content depend mostly on amplitude- (m_a) and frequency modulation indexes (m_f), Fig. 11:

$$m_a = \frac{U_{control}}{U_{D/2}} \quad m_f = \frac{f_{swich}}{f_1} \quad (31)$$

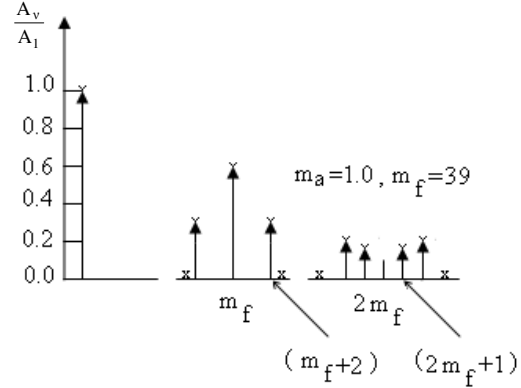

Fig. 11: Part of typical amplitude harmonic spectrum

Harmonic components can be compute using above methodology and work [2]. For modulation indexes $m_a = 0,2$ and 1 and $m_f = 39$ resulting amplitudes are given in Tab. 1.

v \ m _a	0,2	1,0
1	0,2	1,0
m _f	1,242	0,601
m _f ± 2	0,016	0,318
m _f ± 4		0,018
2m _f ± 1	0,190	0,181
2m _f ± 3		0,212
2m _f ± 5		0,033
3m _f	0,335	0,113
3m _f ± 2	0,044	0,062
3m _f ± 4		0,157
3m _f ± 6		0,044
4m _f ± 1	0,163	0,068
4m _f ± 3	0,012	0,009
4m _f ± 5		0,119
4m _f ± 7		0,050

Tab. 1: Calculated Fourier coefficients (c_v) for $m_a = 0,2$ and 1 and $m_f = 39$

Current time-waveforms for v-harmonic components in steady-state are given [2]

$$i_{uv}(t) = \frac{A_v}{Z_v} \cdot \sin(v \cdot \omega \cdot t - \varphi_v), \quad (32)$$

where: $A_v = A_1 \cdot c_v$ - amplitude of v-harmonic component, $A_1 = m_a \cdot U_d / 2$ - amplitude of 1. harmonic component, $|Z_v| = \sqrt{R^2 + (v \cdot \omega \cdot L)^2}$ and $\varphi_v = \arctan(v \cdot \omega \cdot L / R)$

The total current will be summarizing of single harmonics. Simulation experiments have been done for the parameters: $R = 10 \text{ Ohm}$, $L = 25 \text{ mH}$, $U_d = 300 \text{ V}$, $f = 50 \text{ Hz}$ at $m_a = 1$, $m_f = 39$, time increment $\Delta t = 5 \mu\text{s}$. Simulation results are given in Fig.12 and Fig.13.

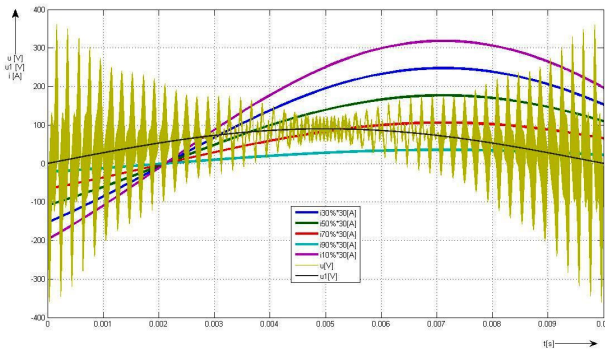

Fig. 12: Time waveform of voltage (1. harmonic component) and load current of IM – with various counter-voltage and modulation index of bipolar PWM $m_a=1$ and $m_f=39$

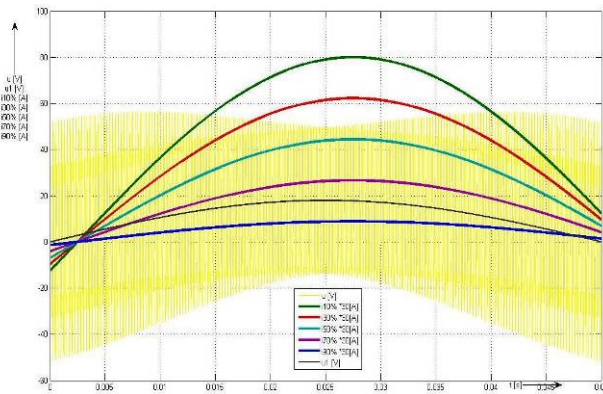

Fig. 13: Time waveform of voltage (1. harmonic component) and load current of IM – with various counter-voltage and modulation index of bipolar PWM $m_a=0.2$ and $m_f=39$

2 CONCLUSION

The relation for resulting time-waveforms of line-to-line voltages can be obtained also in compact closed form using classical analytical solution, Laplace transform and similar methods.

Anyway, the solution given in the paper makes it possible to analyse more exactly effect of each harmonic component comprised in total waveform on induction motor quantities.

3 ACKNOWLEDGEMENT

The authors wish to thank for the financial support to VEGA Agency for the project No. 1/0470/09, and R&D operational program Centre of excellence of power electronics systems and materials for their components No. OPVaV-2008/2.1/01-SORO, ITMS 26220120003 funded by European regional development fund (ERDF).

4 REFERENCES

- [1] T.J. Takeuchi: Theory of SCR Circuit and Application to Motor Control. Electrical Engineering College Press, Tokyo (JP), 1968 - Russian Edition, Energia Publisher, Leningrad-St. Petersburg (RF), 1973, 248 pp., T 051(01)-73 130-73.
- [2] Biringner P. P. and Slonin M. A., Determination of Harmonics of Converter Current and/or Voltage Waveforms (New Method for Fourier Coefficient Calculations), Part I: Fourier Coefficients of Homogeneous Functions, IEEE Transactions on Industry Applications, vol. IA-16, No. 2, March/April 1980, pp. 242-247.
- [3] Biringner P. P. and Slonin M. A., Determination of Harmonics of Converter Current and/or Voltage Waveforms (New Method for Fourier Coefficient Calculations), Part II: Fourier Coefficients of Non-Homogeneous Functions, IEEE Transactions on Industry Applications, vol. IA-16, No. 2, March/April 1980, pp.248-253
- [4] N. Mohan, T.M. Undeland, W.P. Robbins: Power Electronics: Converters, Applications, and Design. John Wiley & Sons, Inc., ISBN 0-471-42908-2
- [5] R.H. Park: Two Reaction Theory of Synchronous Machine. Generalized Method of Analysis – Part I. IEEE Transactions, Vol. 48, July 1929, pp. 716-730
- [6] Záskalický, P., Záskalická, M.: Complex Fourier Series Model of a Voltage Three-Phase Source Inverter. In: *Acta Electrotechnica et Informatica, TU Kosice (SK)*, vol. 9 (2009), ISSN 1335-8243 – accepted paper
- [7] Záskalický, P., Záskalická, M.: Behaviour of the Two-phase Permanent Magnet Synchronous Motor Supplied by Triacs from Single-Phase Voltage. In: *Acta Electrotechnica et Informatica, TU Kosice (SK)*, vol. 5 (2005), no. 3, pp. 1-5, ISSN 1335-8243
- [8] Gonthier, L., et al.: High-Efficiency Soft-Commutated DC/AC/AC Converter for Electric Vehicles. In: *Journal ElectroMotion 5* (1998), no. 2, pp. 54 – 64, ISSN 1223-057X.
- [9] Dobrucký, B., Šul, R., Beňová, M.: Mathematical Mo-delling of Two-Stage Frequency Converter using Special Methods: Complex Conjugated Magnitudes and Orthogonal Park/Clarke Transformation Ones. In: *Journal of Applied Mathematics*, vol. II, no. III, 2009, ISSN 1337-6365.
- [10] Dobrucký, B., Benova, M., Spanik, P.: Using Complex Conjugated Magnitudes- and Orthogonal Park/Clarke Transformation Methods of DC/AC/AC Frequency Converter. In: *Electronics and Electrical Engineering 5/2009*, LT, pp. 29-34, ISSN 1392-1215

Mariana Beňová, Ing. PhD., University of Zilina, Faculty of Electrical Engineering, Univerzitná 1, 01026, Žilina, benova@fel.uniza.sk,

Branislav Dobrucký, prof. Ing. PhD., University of Zilina, FEE, dobrucký@fel.uniza.sk,

Róbert Šul, Ing., University of Zilina, FEE, robert.sul@fel.uniza.sk