

Transport Actuator with Permanent Magnet

Daniel Mayer*, Bohuš Ulrych*

*University of West Bohemia, Departement of Theory of Electrical Engineering, mail: {mayer@kte.zcu.cz, ulrych@kte.zcu.cz }

Abstract It describes a project supporting element with a permanent magnet, the usable equipment for the transport of ferromagnetic object at greater distances.

Keywords magnetic circuit, permanent magnets, demagnetization process.

I. INTRODUCTION

At various technological operations in engineering and manufacturing of construction crane to transport iron components commonly used electromagnetic clamping plate. These, however, during its activities require the power supply for the electromagnet. In this work is presented first part of the feasibility study for the project clamping plate, equipped with a set of supporting elements with permanent magnets. The supporting element with a permanent magnet (SEPM), however, does not need for its activities supply of electricity, which often greatly simplifies the handling of transport. It is describes the design of the SEPM, is formulated his mathematical model and subsequent computer model, made discussion of results is implied and later assumed direction of further development.

II. FORMULATION OF SOLVED TASK

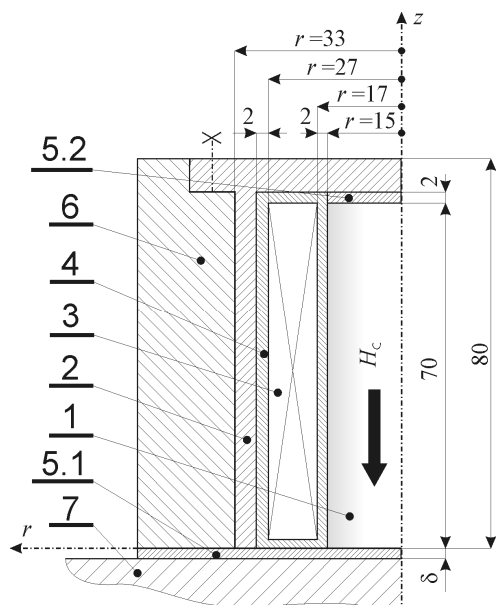

Fig. 1. The arrangement of SEPM

Basic arrangement considered SEPM is shown in Fig. 1. Its basic elements are cylindrical permanent magnet **1**, inserted into the ferromagnetic sheath **2**. On this magnet is wound coil **3**. At the moment it runs off SEPM release current pulse generated by capacitor discharge. This capacitor is placed on the clamping plate **6**, together with the SEPM. Casing **2** is to the non-magnetic clamping plate **6** fastened its flange and any number, according to specific technical requirements.

To fix the ferromagnetic transported load **7** to the clamping plate **6** is sufficient to approach the board with the SEPM in the vicinity to the transported load **7** (at the distance δ , see Fig. 1). The force arises $F_{m,z,7}(I_{off} = 0) > F_G$ (see Fig. 3), where F_G is the weight of the transported load **7**, or parts thereof corresponding to one SEPM under consideration in the clamping plate **6**.

The release of the transported load **7** from the clamping plate **6** is necessary to reduce the drawing force $F_{m,z,7}$ of SEPM so, that $F_{m,z,7}(I_{off} \neq 0) < F_G$ prevailed gravity loads **7** against to the attractive force of SEPM. This is done so that the coil **3**, which is wound on the permanent magnet **1**, bringing the previously mentioned short-term ($\Delta t \approx 0, 01$ s) release current pulse I_{off} . This pulls causes a short-term partial demagnetization of permanent magnet and thus decrease its attractive force.

III. MATHEMATICAL MODEL OF MAGNETIC CIRCUIT CONTAINING SEPM

General equation describing the electromagnetic field in the SEPM, as shown in Fig. 1, according [1], [2], has the form

$$\text{rot} \left(\frac{1}{\mu} \text{rot} \mathbf{A} - \mathbf{H}_c \right) = \mathbf{J}_{off} \quad (1)$$

where for magnetic vector potential the equation hold true

$$\mathbf{A} = \mathbf{r}_0 0 + \mathbf{z}_0 0 + \Phi_0 A_\varphi(r, z) \quad (2)$$

From equation (1) can be easily obtain the specific forms of equations describing the magnetic field in each sub region considered definition domain of SEPM.

Vector of attraction force generated by the considered SEPM is then, according to [2], given by

$$\mathbf{F}_m = \frac{1}{2} \oint_s [\mathbf{H}(\mathbf{nB}) + \mathbf{B}(\mathbf{nH}) - \mathbf{n}(\mathbf{HB})] dS \quad (3)$$

IV. NUMERICAL SOLUTION AND DISCUSION OF RESULTS

Numerical solution of a mathematical model considered SEPM, whose shape is described in paragraph 3 was carried out by FEM with program QuickField 5.0 [3]. For the calculations were considered permanent magnet form rare earth with powder technology (Fe, 40% Co) [4], the nonlinear construction carbon steel 12 040 [5]

and the coil of copper wire, $N_z = 680$, $D_v = 1$, mm, $\kappa = 0.785$. For illustration a few obtained results are presented.

A. QUALITATIVE RESULTS

By comparing Fig. 2a and Fig. 2b can be a perception of the effect of a demagnetizing current pulse I_{off} in the coil **3** on the magnetic field of considering permanent magnet **1** of the SEPM. It is obvious that at sufficiently strong current pulls I_{off} ($I_{off} \approx 63$ A,) there is complete suppression of the magnetic field of permanent magnet (compare the Fig. 3). This would lead to its destruction and is therefore technically unacceptable (see also paragraph 5).

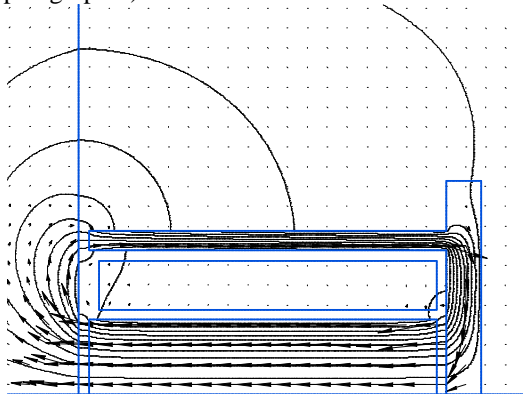

Fig. 2a. The magnetic field of permanent magnet **1** without causing a current demagnetised pulse I_{off} ($\delta = 2$ mm, $I_{off} = 0$, scale $7 \cdot 10^{-5}$ Wb/m)

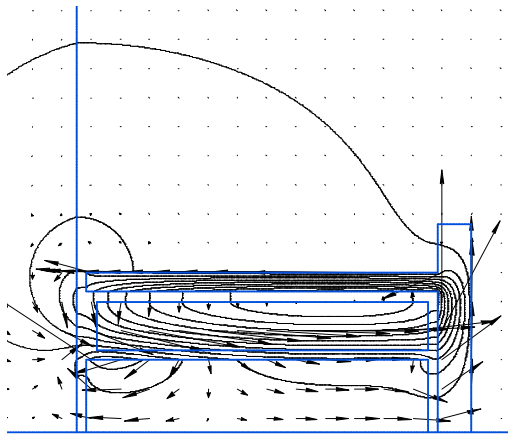

Fig. 2b. Permanent magnet **1** demagnetization effects by action of a current pulse I_{off} ($\delta = 2$ mm, $I_{off} = 63$ A, scale $7 \cdot 10^{-5}$ Wb/m)

B. QUANTITATIVE RESULTS

Let us define value of demagnetization by the relationship

$$d_m = \frac{B_m(I_{off} = 0)}{B_m(I_{off})} - 1$$

In Fig. 3 is a characteristic of the considered SEPM. Hence it is clear that for $I_{off} = 0 \rightarrow d_m = 0$ valid for the intended permanent magnet $B_{m,avrg} \approx 1$ T and the corresponding attractive force is. $F_{m,z,7} \approx 210$ N. Then for the selected safety interval $\Delta F = 20$ N is the maximum weight $F_{G,max} \approx 190$ N that can be raised with SEPM under consideration. If, by contrast, used the off

current $I_{off} = 54.5$ A, which corresponds to $B_{m,avrg} \approx 0.5$ T $\rightarrow d_m \approx 1$, attractive force of considered SEPM is reduced to

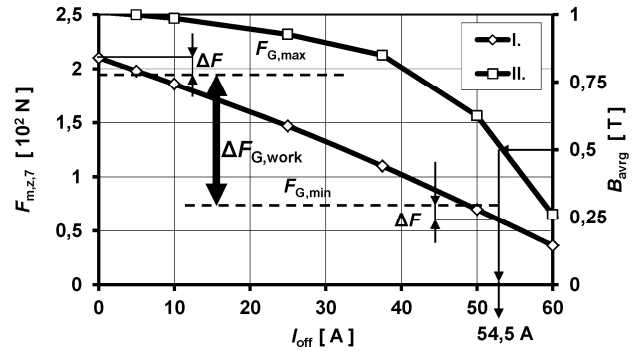

Fig. 3. Quantitative scheme operating mode of considered SEPM ($\delta = 2$ mm, $I \approx F_{m,z,7}$, $II \approx B_{avrg}$)

$F_{m,z,7} \approx 57$ N. This corresponds to (with the same $\Delta F = 20$ N) minimum weight, which is due to the gravity separated from the considered SEPM $F_{G,min} \approx 77$ N. Then the work interval considered SEPM, ie the interval at which it can find the weight of transported loads **1**, is $\Delta F_{work} \approx \langle F_{G,min}, F_{G,max} \rangle$ in the given case $\Delta F_{work} \approx \langle 77, 190 \rangle$ N. It is assumed (see also paragraph 5) that the demagnetization $d_m \approx 1$ ($B_{m,avrg} \approx (1 \rightarrow 0.5)$ T) considered of a permanent magnet is still reversible and does not lead to his destruction.

VI. CONCLUSION

The present study show how the implementation of the supporting element for the transport of ferromagnetic object that its activity does not need a power supplies. Further work will focus on electric circuit design generating demagnetizing current pulse as a discharge of capacitor. It would also be appropriate to interpret the process of partial demagnetization of permanent magnet as a movement of working point at the demagnetizing branch of the hysteresis loop.

VII. ACKNOWLEDGEMENTS

This work has been financially supported from the Research Project *Diagnostics of interactive phenomena in electrical engineering*, MSM 4977751310

VIII. REFERENCES

- [1] Furlani E. P.: Permanent Magnet and Electromechanical Device. Academic Press, New York 2001.
- [2] Haňka L.: Electromagnetic Field Theory. SNTL/ALFA, Praha 1975. (In Czech)
- [3] www.quickfield.com
- [4] Hassdenteufel J., Květ K.: Electrotechnické materiály, SNTL Praha, 1967
- [5] Skoda Works Standard 00 6004