

Elimination of the Leakage Inductance of the Primary Winding of an Impulse Transformer for a Contact-less Temperature Gauge

M. Kadlečíková¹, M. Kolmačka¹, J. Breza¹, L. Vančo²

¹ Slovak University of Technology in Bratislava, Faculty of Electrical Engineering and Information Technology
Ilkovičova 3, 812 19 Bratislava, Slovakia

² Slovak University of Technology in Bratislava, STU Center for Nanodiagnostics,
Vazovova 5, 812 43 Bratislava, Slovakia

E-mail : magdalena.kadlecikova@stuba.sk

Abstract

We continue in reconstruction of the temperature meter with optical transmission of temperature reading in the HF CVD reactor. The parasitic inductance causes degradation of the transformer. The issue is solved by including a non-dissipative snubber that recuperates the energy from the parasitic inductance back to the power supply and allows faster demagnetization, thereby improving the transfer of energy through the transformer to its secondary winding.

Key words

Hot filament chemical vapour deposition (HF CVD).

INTRODUCTION

We prepare nanocomposites with carbon nanotubes (CNTs) directly in situ in the HF CVD reactor. The hot tungsten carbide filaments are used as a source of energy that are placed in vacuum above the substrate. The deposition conditions are optimized by modifying the voltages, flow rates of gases (methane and hydrogen), temperature and time of synthesis. The working atmosphere was a mixture of methane and hydrogen. The precursors are activated by five filaments heated up to 2200 °C. The pressure and temperature during deposition were 3000 Pa and 620 °C, respectively. The time of synthesis was 25 minutes. The technology of hybrid nanomaterials, step by step, is in our laboratory reproducibly mastered.

EXPERIMENTAL

The system for optical transmission of temperature reading in a HF CVD reactor during pyrolysis of methane and hydrogen for

synthesis of carbon nanotubes was described in detail in [1-3]. The main problem lies in deposition of conductive impurities on the thermocouples, which leads to a decreased accuracy or complete failure of temperature measurement. Another problem is the interruption of the ± 12 V voltage from the external supply due to unreliability of the sliding annular copper contacts between the



Fig. 1 Parts of the HF CVD system below the vacuum jar. One can see the rotary mechanism, sliding annular contacts, outputs of the thermocouples (grey cables) and temperature compensation (blue connection).

static and moving parts of the apparatus (Fig. 1).

The presented solution consists in galvanic separation of the thermocouples and in replacing the sliding annular contacts by a DC-DC converter. A high-frequency switched supply was designed with a switching frequency of 60 kHz. We chose the topology with a flyback converter comprising a pot-shaped ferrite core transformer, a switch, a diode and two capacitors [4].

The advantage of the flyback topology is the possibility of simple energy recovery from the leakage inductance of the primary winding. For eliminating the voltage peaks caused by the leakage inductance when the transistor is switched off it is a common practice to use a damping element that recuperates the energy from the dissipation inductor back to the power source while allowing faster demagnetization, thereby improving the transfer of energy through the transformer to its secondary winding. We implemented the active element and adjusted the damping element (Fig. 2) that maintains the connection of the collector of transistor M1 and capacitor C1 only at the time of

switching on of transistor Q10. A higher energy transfer efficiency was observed of the transformer core to its secondary side by incorporating transistor Q10 to separate the primary winding from the damping element when the leakage inductance is fully demagnetized and the primary winding current drops to zero without demagnetization of L2.

Transistor Q10 is switched on at the moment of switching on transistor M1, whereby the collector of transistor M1 is connected to the capacitor of the damping element C1. The switching-on of transistor Q10 provides the current that enters the base of Q10 through resistor R28 and capacitor C26 with Zener diode D41. At the moment of opening transistor M1, the potential of the collector M1 and emitter Q10 increases above the level of the supply voltage, which causes transistor Q10 to close with the loss of its base current. Diode D26 is forward biased and the primary inductance L_p is reset along with the leakage inductance LLT. After the reset current drops, diode D26 is reverse biased and the collector potential M1 can drop without any current flowing through the primary winding. At the same time, the core of coil L2 is

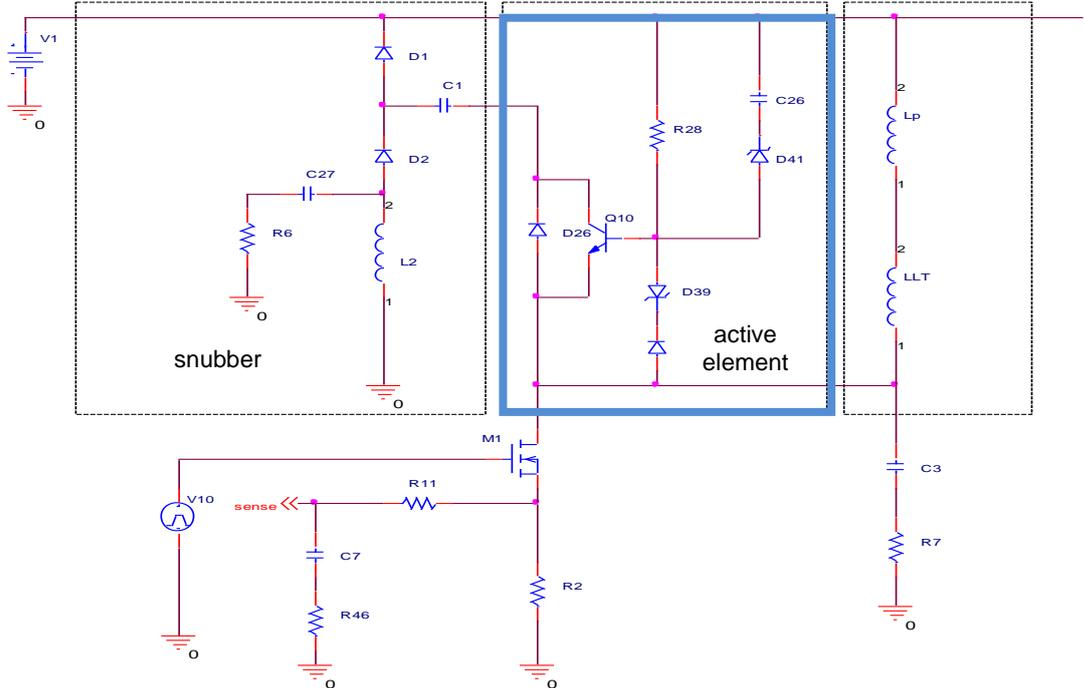

Fig. 2 Connection of the active member and of the snubber

demagnetized without affecting the primary winding of the transformer. Zener diode D39 and diode D40 perform a protection function to avoid destroying the base-emitter junction of transistor Q10 in reverse polarization.

CONCLUSION

In summary, we designed and implemented a power supply that is structurally unique in that its output terminals have mechanical freedom and thus the ability to rotate without the use of contacts. Energy transfer is mediated by the magnetic field in the pot-shaped ferrite core transformer. Subsequently, we solved the problem of the higher value of leakage inductance by changing the transformer winding arrangement.

ACKNOWLEDGEMENT

We are grateful to the scientific grant agency VEGA of the Ministry of Education, Science, Research and Sport of the Slovak Republic for financial support of project No. 1/0532/19 and to the Slovak Research and Development Agency, contract No. APVV-17-0169.

REFERENCES

- [1] Kolmačka, M., Kadlečíková, M., Breza, J., Lazišťan, F., Zajíčková, L., Eliáš, M., Jesenák, K., *Journal of Electrical Engineering*, 60 (2009) pp. 346-349, ISSN 1335-3632.
- [2] Kadlečíková, M., Breza, J., Klotton, G., Kolmačka, M., Vančo, L., In: *1st International Microelectronics Assembly and Packaging Society Conference 2015*, Brno, pp. 32-33, ISBN 978-80-214-5270-1.
- [3] Kadlečíková, M., Breza, J., Klotton, G., Kolmačka, M., Vančo, L., *Electroscope*, Issue I (2016) ISSN:1802-4564.
- [4] Dostál, J., *Operační zesilovače*, 2. vydanie, Vydavateľstvo BEN – technická literatúra, ISBN: 8073000490, 504 s. (2005)