

# Electronic Control Board for Phased Antenna Array Research and Prototyping

Michal Pokorný  
Faculty of Electrical Engineering  
University of West Bohemia  
Pilsen, Czech Republic  
mpokorny@fel.zcu.cz

Ivo Vertat  
Faculty of Electrical Engineering  
University of West Bohemia  
Pilsen, Czech Republic  
ivertat@fel.zcu.cz

Jiri Masopust  
Faculty of Electrical Engineering  
Czech Technical University  
Prague, Czech Republic  
masopjir@fel.cvut.cz

**Abstract**— Current state-of-the-art phased antenna arrays used in modern generations of mobile networks and radars in terrestrial applications or as spacecraft antennas in space applications tend to be very complex and expensive devices with many mutually coupled elements and many input/output ports that are excited with varying amplitude and phase. Also, the simulation and design of such complex antenna arrays may not be accurate due to many sources of uncertainty, such as inhomogeneity of high-frequency substrate properties over large area, manufacturing tolerances, idealized component models, etc. Therefore, simpler solutions of these antenna arrays in the form of sparse arrays, non-uniform arrays or arrays with parasitic elements are intensively studied. In this paper, we present an experimental electronic control board, which is used in our research of simplified phased array antennas. This digitally controllable board, in addition to the commonly used changes in the amplitude and phase of the propagated signal, can connect the individual antenna elements to a programmable impedance load, variable in the capacitive and inductive range. The aim of the implementation of this control electronic board is to study the influence of the mutual couplings of actively excited elements of the antenna array and parasitic elements loaded by variable impedance load on the resulting properties of the antenna arrays.

**Keywords**—antenna array, phasing circuits, electronic impedance load, antenna array control

## I. INTRODUCTION

In terrestrial applications, the massive antenna arrays are used in modern generations of cellular mobile networks, where they are able to offer high data rates by implementation of electronic beamforming toward the predicted positions of user terminals [1]. Such antenna arrays have also found application in radars, where they offer the creation of multiple beams and the ability to track multiple targets at once without the need for mechanical rotation [2]. In space applications, large antenna arrays are commonly used in the spacecrafts on the Earth's orbits for creation of spot beams to cover independent ground cells by signal [3] and also for deep space communication [4], where they can reduce the accuracy and power requirements of attitude control systems and simplify the mechanical design of high-gain antennas (flat phased antenna arrays as a more reliable replacement for mechanically deployable reflector antennas). Some studies for the ground stations are also being developed using large phased array antennas for space missions [5], [6], [7], as it will be useful for future ground stations to be able to track more than one satellite at a time as new satellite mega-constellations (e.g. Starlink, OneWeb, Telesat, Hongyan) or smaller satellite constellations for IoT (e.g. Hiber, Swarm, Astrocast, Kepler, Lacuna, Myriota, Fleetspace) are under massive development.

Massive antenna arrays have a large number of mutually coupled elements and a large number of ports with phasing circuits and variable gain amplifiers. With the number of actively controlled ports, the cost of implementing the antenna array increases as well as the complexity of the feeding network. Due to the many sources of uncertainty, it is necessary to address the complex issues of calibration of such phased array arrays. There are a large number of studies on the topic of antenna array calibration, e.g. [8], [9], [10], using different approaches.

Methods of simplifying antenna arrays by reducing the number of actively excited elements while maintaining the required properties of antennas are also a very common topic of research. These researches lead to the study of the properties of sparse antenna arrays [11], [12], [13], non-uniform arrays [14], [15], [16] and arrays with parasitic elements [17], [18], [19]. However, the results of simulations of these series should also be based on experimental verification, because the simulations do not have to give accurate results due to the limited accuracy of the used substrate and component models.

For this reason, we propose an electronic control board for testing prototype antenna arrays as part of our broader research on simplified antenna arrays solution and their design methods. The rest of the paper is organized as follows: Chapter II describes brief requirements for electronic control board used in testing of our simplified antenna arrays and block diagram of this control board. Design and individual parts (phasing circuits, variable attenuators, variable impedance load circuits, and microprocessor circuit) of proposed board will be outlined in the main chapter III. Chapter IV concludes the results and possible future work in this area.

## II. CONCEPT OF ELECTRONIC CONTROL BOARD

The main functionality of the antenna array beamforming front end is fluently changing the attenuation and phase shift of the signal to required values. Phase shifters and attenuators are usually passive circuits with its own loss, which causes signal to noise ratio degradation. Therefore, the front end for each antenna element has to contain separate RX/TX switches, low noise amplifier (LNA), power amplifier (PA), phase shifter and attenuator. This is the simplest front end configuration to ensure the acceptable signal parameters (comparable with classical antenna configuration with motorized steering). Only the output power of the PA is in absolute value divided with numbers of antenna elements in array (total power is distributed across the elements of array).

But the requirements for the modern beamforming front ends have quite wider range of options than RX/TX function. They must also support the defined impedance matching, if it is necessary to switch off any antenna element (e.g. for non-uniform antenna arrays). Sometimes it is also important to be able to switch the polarization of the individual elements of the array. In our project we tried to design the convenient antenna beamforming front end for ensuring a wide range of requirements that this device must fulfill for experimental testing.

### A. The Purpose of Developing and the Requirements

The aim of the development was to implement an electronic control board that would be able to control the amplitudes and phases of the propagated signal from or to the individual patch elements of the antenna array and add several more options for better testing and research of antenna arrays. The developed board serves to support our cooperation on the research into the design of simplified antenna arrays with quantized control, where some elements of the antenna array could only loaded parasitic elements. Therefore, one of the requirements for the control board was the ability to load any of the elements of the array with electronically controlled impedance load. The 2.4 GHz ISM band was chosen for the implementation of the prototype, because there are a large number of interesting applications where antenna arrays can be used, such as rotator-less ground stations for satellite communications or for controlling ground based or aerial drones. However, such applications often require the ability to switch the polarization of the antenna array.

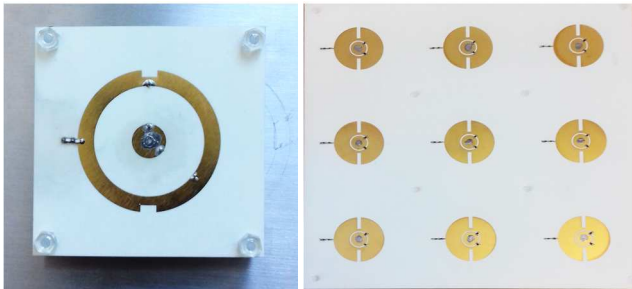

Fig. 1 Prototype of C-shaped patch element with selectable RHCP / LHCP polarization and prototype of simplified antenna array 3x3.

C-shaped patch element (fig.1 left) based on [20] with switchable RHCP / LHCP polarization via two pin diodes was chosen as the basic element of antenna array for testing of quantized method of control. Slightly redesigned similar patch element was used for the test prototype of 3x3 antenna array (fig.1 right). Therefore the proposed control board for this array must be able to switch the polarization of patch element using the DC bias current distributed into two pin diodes through the RF signal path.

### B. Block Diagram of the Control Board

The proposed electronic control board for the development and prototyping of antenna arrays has a RF signal path part, which is individual for each controlled element of antenna arrays and common interface part controllable via USB from the PC. Fig. 2 shows the block diagram of part with RF signal path. It consists of receiver path with low noise amplifier LNA, transmitter path with power amplifier PA, phase shifter PS, controllable attenuator ATT, programmable impedance load Z, switches SW for RF signal routing, simple logic for switches control and current source IS for the switching of

antenna element polarization via the bias tee connection into the RF path.

Such solution of front end signal path can work in half duplex operation. This can be controlled with driving signals and the proposed unit could work in three modes, RX – receiving signals from antenna element, TX – transmitting signals to antenna element and IMP – programmable impedance loading of the antenna element.

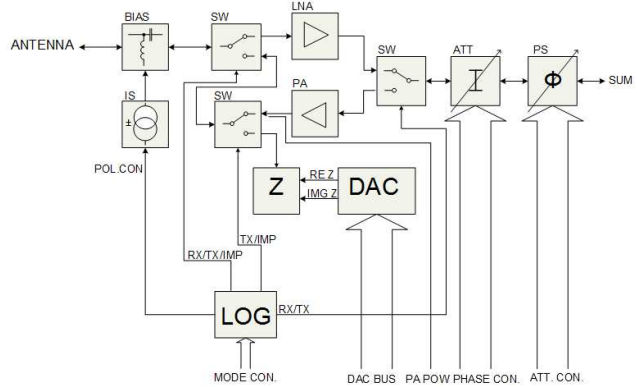

Fig. 2 Block diagram of individual RF signal part of electronic control board for antenna array development.

Common interface part (fig. 3) consists of microcontroller CPU with USB connection to PC, summing circuit for combining / dividing signals from / to up to 9 antenna array elements, multiplexer circuits MUX for independent setting of amplitude, phase and impedance load in all array elements and serial to parallel converter for logic circuit control in all elements to control switching between RX and TX operation, RHCP and LHCP polarization of elements and their eventual programmable impedance loading.

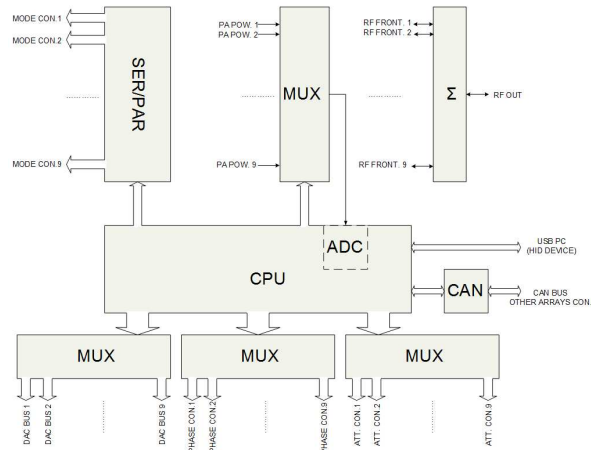

Fig. 3 Block diagram of common interface part of electronic control board for antenna array development.

One multiplexer sequentially senses the state of all power amplifiers in TX signal path through embedded analog to digital converter in microcontroller.

## III. ELECTRONIC CONTROL BOARD DESIGN

In the receiving signal path of the front end, there is a low noise amplifier design (fig. 4) with QPC9314 integrated circuit from Qorvo manufacturer, based on E-pHEMT technology. The noise figure of this circuit is 1.2 dB with gain

33 dB in high gain regime or 24 dB in low gain regime. This LNA circuit has also embedded low loss RX/TX switch at the input, which is used in our design for switching between RX mode and TX/IMP mode of our proposed control board. This switch has insertion loss 0.5 dB and handle to forward up to 52 W of RF power into antenna element during TX mode.

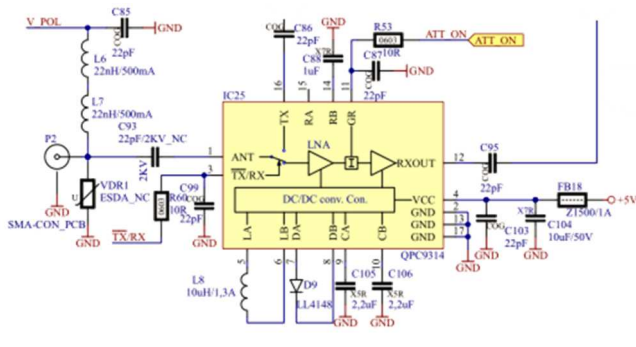

Fig. 4 Schema of low noise amplifier part of proposed electronic control board for antenna array testing, using QPC9314 circuit.

In the transmitting signal path of the front end, there is a power amplifier design (fig. 5) with RFFM4200 integrated circuit from Qorvo manufacturer, implementing three-stage power amplifier, filtering, TX/RX switch and power detector. The output power of this circuit is up to 25 dBm. Its embedded TX/RX switch is used as TX/IMP switch in our design, which allows to route the power amplifier output of RFFM4200 or our programmable impedance load to the antenna element through the embedded switch in LNA circuits QPC9314, described in the previous paragraph and plotted in block diagram (fig. 2).

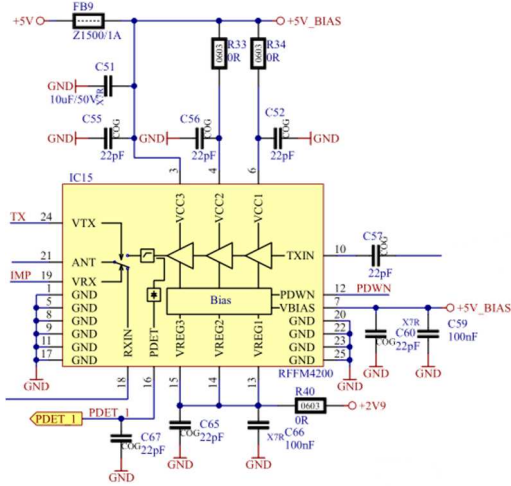

Fig. 5 Schema of power amplifier part of proposed electronic control board for antenna array testing, using RFFM4200 circuit.

The variable impedance load (fig. 6) was designed to enable also testing of non-uniform antenna array or sparse antenna array, where some antenna elements of array can be disconnected and loaded by programmable impedance to act as a parasitic element only. It consists of serial connected PIN diodes BAP64 for the real part impedance changing (due to the serial current regulation) and serial varactors SMV1247 for imaginary impedance character changing (due to the cathode - anode voltage tuning). Current and voltage source are driven by dual 14-bit D/A converter MCP48CVB22-E from microcontroller part.

The output from low noise amplifier section and the input to the power amplifier section is connected with common section consisting of phase shifter and step attenuator through the external integrated circuit HMC574ASM8E with SPDT type of low loss switch from Analog Devices manufacturer. This section with programmable digital phase shifter and step attenuator (fig. 7) is required for antenna array beamforming.

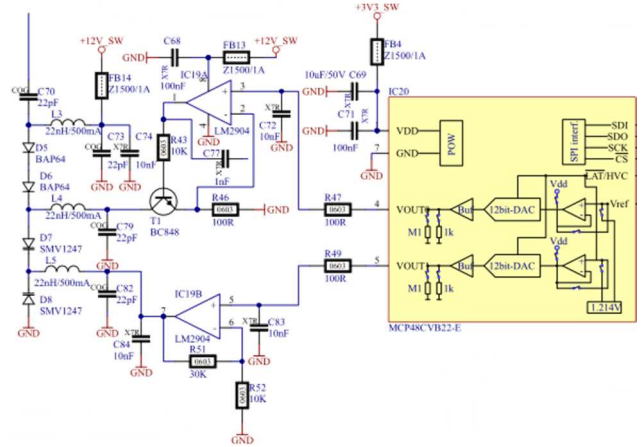

Fig. 6 Schema of programmable impedance load for antenna array testing with disconnected and impedance loaded parasitic elements.

The phase shifter is the integrated PE44820 circuit from Peregrine Semiconductor manufacturer with 1.4° resolution, 8-bit representation of control word, low phase error (RMS 1°) and low amplitude error (RMS 0.1 dB). This circuit is followed by the digital 7-bit step attenuator PE43705 from Peregrine Semiconductor manufacturer. The insertion loss in desired frequency band 2.4 GHz is approx. 2 dB with programmable attenuator range 0 dB – 31.75 dB with step 0.25 dB. Both circuits (phase shifter and step attenuator) are controlled via SPI interface from microcontroller part of proposed board.

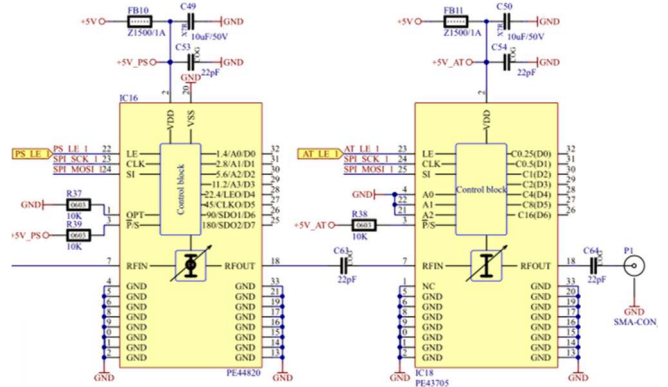

Fig. 7 Schema with phase shifter PE44820 and step attenuator PE43705 part of proposed electronic control board for antenna array testing.

For our testing antenna array with 3x3 elements it is necessary to use and control 9 RF frontends with previously described low noise amplifier part, power amplifier part, impedance load part, phase shifter part and step attenuator part. Each RF front end has also its own control logic circuits 74LVC series (fig. 8) for driving signal for switches and for saving the I/O pins of microcontroller. In this part of electronic control board the logic circuits generates all required signals for selection of TX mode (the antenna element is used for the signal transmission), RX mode (the antenna element is used for the signal reception) or IMP mode (the antenna element is

disconnected and loaded by variable impedance to create parasitic antenna element) based on the driving control signals from microcontroller.

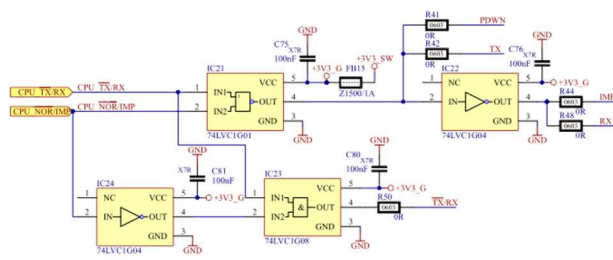

Fig. 8 Schema of logic circuits with 75LVC series for switches driving with limited number of microcontroller I/O pins.

The main part of our proposed electronic control board is microcontroller STM32F103 ARM Cortex-M3 (fig. 9), which has limited I/O ports numbers. In our project, this microcontroller part is shared and will be used for control of 9 front ends of testing antenna array with 3 x 3 antenna elements, but it is capable to control up to 16 front ends via multiplexer part. This proposed electronic control board could be fully controlled (phase shifts, attenuations, impedance values, modes of operation, types of polarization for all connected front ends) via USB HID protocol from PC. If larger antenna array than 16 elements have to be tested, more electronic control boards can be used and controlled via CAN bus, all controlled from PC through USB to CAN interface.

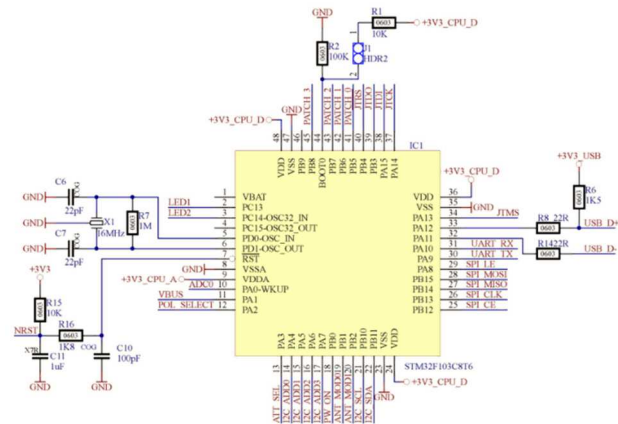

Fig. 9 Schema of microcontroller part of proposed electronic control board with STM32F103 for antenna array testing.

Due to limited number of I/O microcontroller pins, control signals, data signals and state signals of front ends have to be multiplexed via analog multiplexer, digital multiplexer and serial to parallel convertor. The multiplexer circuits for the state signals from power amplifier detectors (feedback sensing of RF power output level) and data signals to DA convertor (controlling of impedance load) are shown in fig. 10. The multiplexer circuits for the data signals of phase shifters and step attenuators are shown in fig. 11.

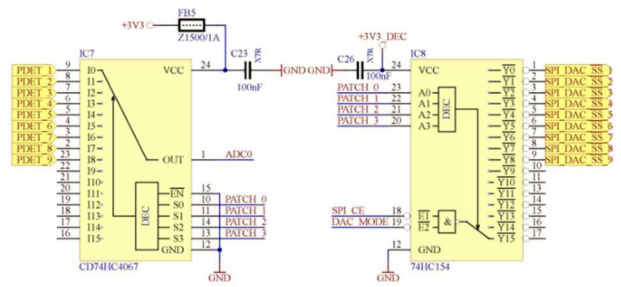

Fig. 10 Schema of multiplexer part of proposed electronic control board – 74HC154 (controlling of impedance load) and CD74HC4067 (feedback from power amplifier).

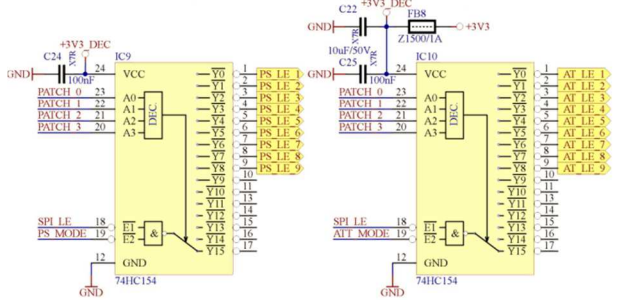

Fig. 11 Schema of multiplexer part of proposed electronic control board – left 74HC154 (controlling of phase shifters) and right 74HC154 (controlling of step attenuators).

Some applications also requires the option of polarization switching (e.g. the ground control stations for satellite commanding), which is in the area of our interest. Therefore our prototype antenna array uses C-shape patch element with selectable RHCP and LHCP polarization. The polarization is controlled via two PIN diodes as switches, integrated directly in patch elements. Switching signal in the form of DC current is created in the circuit shown in fig. 12, controlled by microcontroller and injected into RF signal path via bias-tee (left upper part of fig. 4 with two inductors).

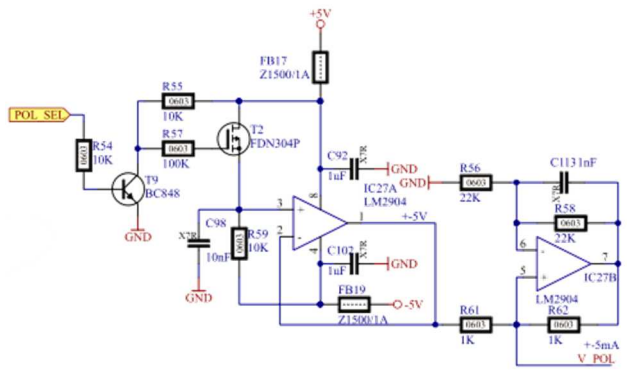
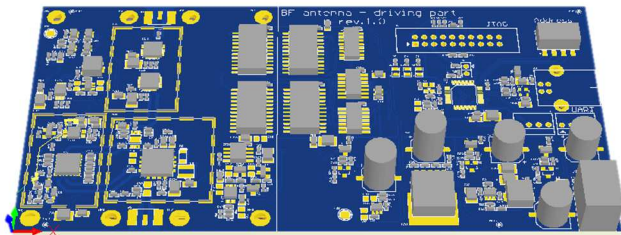

Fig. 12 Schema of polarization selector part of proposed electronic control board for antenna array testing.

CAD model of designed electronic control board is shown in fig. 13. The left part contains all required circuits for one front end (LNA, PA, impedance load, switches, and polarization selector) of one front end. The right part contains common parts (microcontroller with USB and CAN bus interfaces and multiplexers for the distribution of control, data and state signals) for up to 15 other external front ends.

Assembled electronic control board, firmware of microcontroller and PC desktop control software are at present fully functional in prototype version. Wide range of RF

calibrations and measurements related to the beamforming (impedance load tuning, amplitude variations of phase shifter, phase variations of step attenuator, S-parameters) are under the process.



**Fig. 13** CAD model of proposed electronic control board with one front end and common interface/control part for up to 16 front ends.

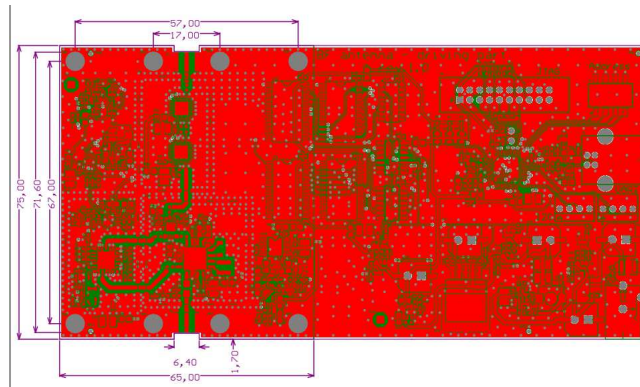

**Fig. 14** Printed circuit board layout of proposed electronic control board with labeled dimensions of front end part.

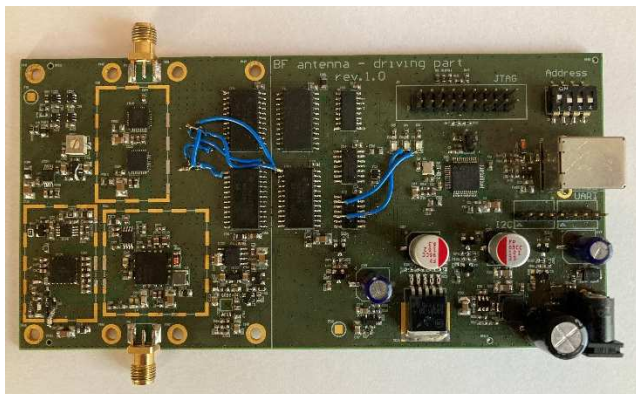

**Fig. 15** Realized prototype of proposed electronic control board with small corrections of control signal wirings.

Realized prototype (fig. 15) of electronic control board for antenna array testing reports gain approx. 17 dB with noise figure better than 1 dB (at frequency 2.4GHz). The power amplifier can supply antenna element with 0.2 W of RF power.

#### IV. CONCLUSIONS

In this paper, we described the development of complete electronic control board for testing of antenna arrays, which is currently used for research in the area of quantized control of simplified antenna arrays and in the future it also allows us to test larger antenna arrays with non-uniform and sparse distribution of antenna elements. Our design is targeted for the satellite communication in S-band (2.4 GHz), but it can be generally used also for the other applications. Described solution ensures receiving and transmitting functionality in half duplex mode, and as addition to general beamforming

hardware also the possibility of disconnection (from PA and LNA signal path) of individual antenna element and its defined impedance matching. Such disconnected elements act as passive parasitic elements in the antenna array and allows us to study their influence on performance of non-uniform or sparse antenna arrays. Another novel properties of proposed solution is the ability to control the polarization of individual compatible patch element via DC current injected into RF signal path.

Proposed solution reaches in the reception signal path the gain 17 dB and noise figure lower than 1 dB at 2.4 GHz band. In the transmission signal path, the board is capable to supply 0.2 W of RF power to each antenna element. Such results are promising to use this electronic control board and RF front ends in the future development of large antenna arrays required for rotator-less ground station for satellite communication.

#### ACKNOWLEDGMENT

This project was supported by Czech Science Foundation under the project number 20-02046S (Antenna Arrays with Quantized Controlling).

#### REFERENCES

- [1] A. E. Ismail, M. Nordin, "Beamforming techniques for massive MIMO systems in 5G: overview, classification, and trends for future research," *Frontiers Inf Technol Electronic Eng* 18, 753–772 (2017). <https://doi.org/10.1631/FITEE.1601817G>.
- [2] M. C. Narasimhamurthy, G. V. Jayaramaiah, "Implementation of Embedded Multi target Tracking System Algorithm for Active Phased Array Radar," *INTERNATIONAL JOURNAL OF ENGINEERING RESEARCH & TECHNOLOGY (IJERT)* Volume 07, Issue 01 (January 2018), <http://dx.doi.org/10.17577/IJERTV7IS010031>.
- [3] S. Xia, Q. Jiang, C. Zou, G. Li, "Beam Coverage Comparison of LEO Satellite Systems Based on User Diversification," *IEEE Access*. PP. 1-1. 10.1109/ACCESS.2019.2959824.
- [4] R. Hodges, N. Chahat, D. Hoppe, J. Vacchione, "A Deployable High-Gain Antenna Bound for Mars: Developing a new folded-panel reflectarray for the first CubeSat mission to Mars," *IEEE Antennas and Propagation Magazine*. 2017. PP. 1-1. 10.1109/MAP.2017.2655561.
- [5] J. M. F. González, J. M. I. Alonso, J. G. -G. Trujillo, A. N. S. de Toca and M. S. Pérez, "GEODA-SARAS: Multi-phased array planar antenna design and measurements," *The 8th European Conference on Antennas and Propagation (EuCAP 2014)*, 2014, pp. 423-425, doi: 10.1109/EuCAP.2014.6901782.
- [6] J. G. Trujillo, M. S. Natera, I. Montesinos, M. A. Campo, M. S. Pérez and R. Martínez, "GEODA-GRUA: Adaptive multibeam conformal antenna for satellites communications," *2011 XXXth URSI General Assembly and Scientific Symposium*, 2011, pp. 1-4, doi: 10.1109/URSIGASS.2011.6050354.
- [7] Á. N. S. de Toca, J. M. Inclán-Alonso, J. G. -G. Trujillo, J. M. F. González and M. S. Pérez, "GEODA-SARAS: Multi-phased array planar antenna for satellite communications," *2013 7th European Conference on Antennas and Propagation (EuCAP)*, 2013, pp. 252-253.
- [8] K. Temir, M. S. Akyüz and Y. K. Alp, "Consideration of environmental and functional factors in calibration of antenna integrated active phased array transmitters," *2016 IEEE International Symposium on Phased Array Systems and Technology (PAST)*, 2016, pp. 1-5, doi: 10.1109/ARRAY.2016.7832558.
- [9] Q. Huang, H. Zhou, J. Bao and X. Shi, "Mutual Coupling Calibration for Microstrip Antenna Arrays via Element Pattern Reconstruction Method," in *IEEE Antennas and Wireless Propagation Letters*, vol. 13, pp. 51-54, 2014, doi: 10.1109/LAWP.2013.2296073.
- [10] T. Chalumyan, O. Maas, X. Begaud and B. Huyart, "Active phased antenna arrays calibration method including edge effects and mutual coupling," *2017 11th European Conference on Antennas and Propagation (EUCAP)*, 2017, pp. 1215-1218, doi: 10.23919/EuCAP.2017.7928655.

- [11] M. C. Viganó, D. L. del Río and S. Vaccaro, "Sparse array antennas for satellite mobile terminals," *The 8th European Conference on Antennas and Propagation (EuCAP 2014)*, 2014, pp. 3132-3136, doi: 10.1109/EuCAP.2014.6902491.
- [12] P. Rocca, G. Oliveri, R. J. Mailloux and A. Massa, "Unconventional Phased Array Architectures and Design Methodologies—A Review," in *Proceedings of the IEEE*, vol. 104, no. 3, pp. 544-560, March 2016, doi: 10.1109/JPROC.2015.2512389.
- [13] C. Bencivenni, M. V. Ivashina, R. Maaskant and J. Wettergren, "Design of Maximally Sparse Antenna Arrays in the Presence of Mutual Coupling," in *IEEE Antennas and Wireless Propagation Letters*, vol. 14, pp. 159-162, 2015, doi: 10.1109/LAWP.2014.2357450.
- [14] F. Enache, F. Popescu, D. Depărățeanu, A. Enache and T. Oroian, "Multi-criteria optimization of non-uniform linear antenna array using genetic algorithms," *2016 International Conference on Communications (COMM)*, 2016, pp. 121-124, doi: 10.1109/ICComm.2016.7528328.
- [15] H. H. Tran, C. D. Bui, N. Nguyen-Trong and T. K. Nguyen, "A Wideband Non-Uniform Metasurface-Based Circularly Polarized Reconfigurable Antenna," in *IEEE Access*, vol. 9, pp. 42325-42332, 2021, doi: 10.1109/ACCESS.2021.3066182.
- [16] M. Bosiljevac, M. Casaletti, F. Caminita, Z. Sipus and S. Maci, "Non-Uniform Metasurface Luneburg Lens Antenna Design," in *IEEE Transactions on Antennas and Propagation*, vol. 60, no. 9, pp. 4065-4073, Sept. 2012, doi: 10.1109/TAP.2012.2207047.
- [17] A. Georgiadis and N. B. Carvalho, "A Convex Optimization Approach for the Design of Supergain Electrically Small Antenna and Rectenna Arrays Comprising Parasitic Reactively Loaded Elements," in *IEEE Transactions on Antennas and Propagation*, doi: 10.1109/TAP.2022.3142312.
- [18] Q. Liang, B. Sun and G. Zhou, "Multiple Beam Parasitic Array Radiator Antenna for 2.4 GHz WLAN Applications," in *IEEE Antennas and Wireless Propagation Letters*, vol. 17, no. 12, pp. 2513-2516, Dec. 2018, doi: 10.1109/LAWP.2018.2880208.
- [19] Y. Hong and J. Choi, "60 GHz Patch Antenna Array With Parasitic Elements for Smart Glasses," in *IEEE Antennas and Wireless Propagation Letters*, vol. 17, no. 7, pp. 1252-1256, July 2018, doi: 10.1109/LAWP.2018.2841512.
- [20] K. M. Mak, H. W. Lai, K. M. Luk and K. L. Ho, "Polarization Reconfigurable Circular Patch Antenna With a C-Shaped," in *IEEE Transactions on Antennas and Propagation*, vol. 65, no. 3, pp. 1388-1392, March 2017, doi: 10.1109/TAP.2016.2640141.